

Power Quality Improvement Using Pso Optimization Based Upqc Controller

P.Sowjanya^{1*}, Dr. V. D. Rajaji^{2*}

¹-Final M.Tech Student, Department of EEE, Dr. Y.S.R. College of Engineering and Technology, Acharya Nagarjuna University, Guntur, Andhra Pradesh, India.

²-Assistant Professor, Department of EEE, Dr. Y.S.R. College of Engineering and Technology, Acharya Nagarjuna University, Guntur, Andhra Pradesh, India.

Abstract- To address power quality issues, the unified power quality conditioner, one of the custom power devices in FACTS, is widely utilized in the distribution systems that are voltage- and current-related. The advantage of the recommended UPQC technology is that it can reduce the dc-link voltage without sacrificing its ability to compensate for it. This ground-breaking technique helps in giving the necessary voltage to the UPQC's series and shunt active filters. Through directly linking the system neutral to the distribution system and using it as a filter, such a type of architecture does away with a capacitor in series with the interface's inductor and crossing the active shunt filters are implemented to satisfy the need for the voltage source inverter's fourth leg. This article offers a compelling suggestion additionally.

Introduction

The insulated gate bipolar transistor, gate turn off thyristors, and thyristors are more sophisticated power semiconductor devices, and a number of variations. Power electronics equipment can cause voltage imbalances in three-phase systems as well as excessive neutral currents due to their disturbances. Efficiency is decreased, and the power factor is low as a result of the reactive power load, imbalance, and excessive neutral currents brought on by these injected harmonics. Since there are various loads at numerous distribution terminals, improving power quality is one of the most essential challenges. The term "power quality" describes systemic problems, for example, independent of voltage, it is important to increase voltage levels at the point of common

coupling (PCC) for different distribution voltage levels.

Unified Power Quality Conditioner

Figure 1 demonstrates a block diagram of the unified power quality conditioner. The other non-linear loads connected there will affect the voltage distortion at PCC. In this example, a single DC link capacitor connects two converters, both series and shunt. The load side transmission line is linked shuntly to the first converter, sometimes referred to as a shunt APF. It helps keep a steady dc link voltage and balance load harmonic current. Another converter is created by using series injection transformers, often referred to as a series converter, paired in series with the utility voltage improves in maintaining sinusoidal load voltage.

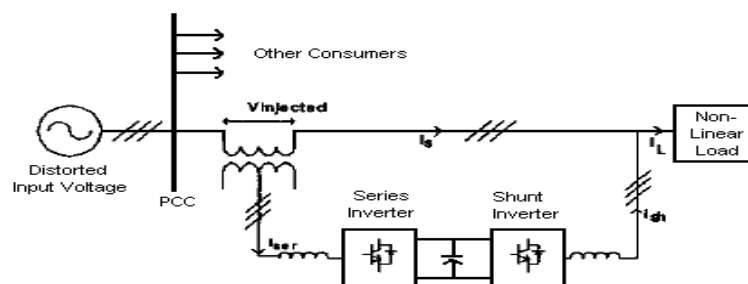

Figure 1: single line diagram of UPQC

The block diagram in figures 2 and 3 is used to construct the controlling method for the UPQC's series and shunt converter.

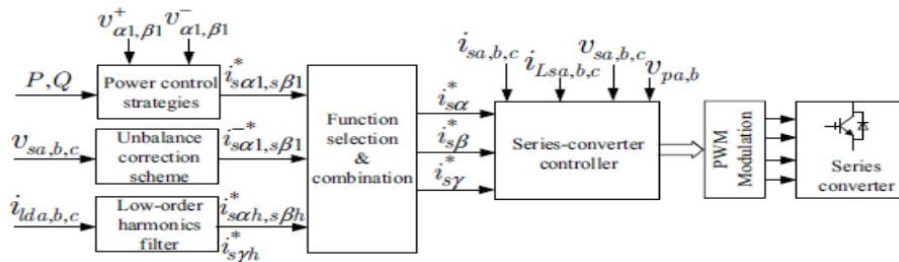

Figure 2 demonstrates a block schematic of the whole control system with a series converter.

The series converter may be utilized to achieve multi-level control objectives, as was covered in the section before this one. As a result, a number of goals may be recognized by the block "function selection and combination" in figure 2. by choosing the appropriate reference signals, which

are $i_{s\alpha}$, $i_{s\beta}$, and $i_{s\gamma}$ [8] in the system. Information about the imbalance correction method, it creates a current reference to balance out negative sequence voltages. Implementing the power control method, to produce the necessary currents for the transmission of reactive and active power.

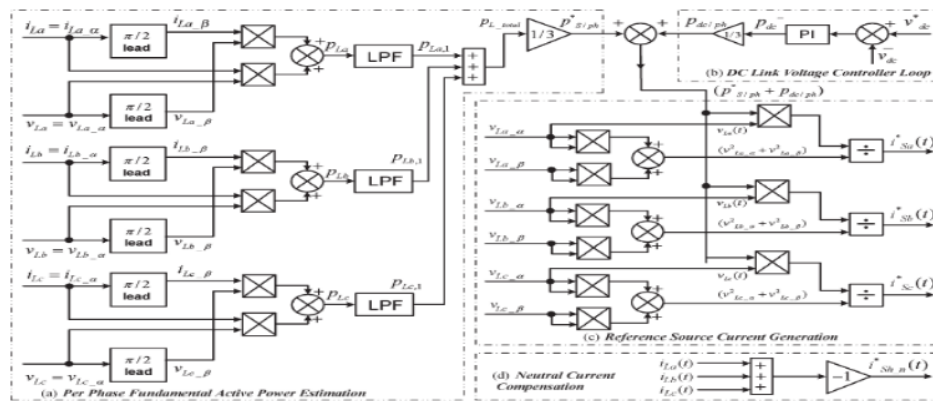

Figure 3 shows a control diagram for a shunt converter.

The load on the three-phase system will assess when the utility's current draw is balanced. The load current imbalance can be rectified by increasing the use of single-phase p-q theory[6]. Because of this, each phase of an unbalanced system may also be treated independently utilizing the balanced three-phase systems p-q theory[2]. The proposed theory states, α - β -coordinates can

be used to define a signal-phase system. The real load voltages and currents are regarded as the $\pi/2$ lead load or $\pi/2$ lag load voltages are considered α -axis quantities and for β -axis values, currents are taken into consideration. In this study, for each phase, a two-phase system is created by taking into consideration $\pi/2$ lead[7]. The voltage at the load and phase a

$$\begin{bmatrix} v_{La_a} \\ v_{Lb_b} \end{bmatrix} = \begin{bmatrix} v_{La}^*(\omega t) \\ v_{La}^*(\omega t + \pi/2) \end{bmatrix} = \begin{bmatrix} V_{Lm} \sin(\omega t) \\ V_{Lm} \cos(\omega t) \end{bmatrix}$$

$$\begin{bmatrix} v_{La_a} \\ v_{Lb_b} \end{bmatrix} = \begin{bmatrix} v_{La}^*(\omega t) \\ v_{La}^*(\omega t + \pi/2) \end{bmatrix} = \begin{bmatrix} V_{Lm} \sin(\omega t) \\ V_{Lm} \cos(\omega t) \end{bmatrix}$$

$$\begin{bmatrix} i_{La_a} \\ i_{La_b} \end{bmatrix} = \begin{bmatrix} i_{La}(\omega t + \varphi_L) \\ i_{La}[(\omega t + \varphi_L) + \pi/2] \end{bmatrix} \quad \begin{bmatrix} i_{La_a} \\ i_{La_b} \end{bmatrix} = \begin{bmatrix} i_{La}(\omega t + \varphi_L) \\ i_{La}[(\omega t + \varphi_L) + \pi/2] \end{bmatrix}$$

Consider the phase a, the active and reactive powers of the phase-a instantaneous load are represented by.

$$\begin{bmatrix} p_{La} \\ q_{La} \end{bmatrix} = \begin{bmatrix} v_{La_\alpha} & v_{La_\beta} \\ -v_{La_\beta} & v_{La_\alpha} \end{bmatrix} \begin{bmatrix} p_{La} \\ q_{La} \end{bmatrix} = \begin{bmatrix} v_{La_\alpha} & v_{La_\beta} \\ -v_{La_\beta} & v_{La_\alpha} \end{bmatrix} \begin{bmatrix} i_{La_\alpha} \\ i_{La_\beta} \end{bmatrix}$$

Where $pp_{La} = \bar{p}_{La} + \tilde{p}_{La}$, $qq_{La} = \bar{q}_{La} + \tilde{q}_{La}$

Analysis of PSO Technique:

The most successful cycles or the best response are the main goals of the figure 4 presents the convergence requirements for the common PSO method. The suggested PSO method [5] would re-initialize and optimize the ideal values of Ki and Kp if the conditions below are satisfied:

$$|v_i(i+1) < \Delta v_i|$$

$$(p_{i1}(k+1) - p_{i1}(k)) / p_{i1}(k) > \Delta p_{i1}$$

The old parameters are represented by Pi (k), whereas the new parameters are represented by Pi (k+1). Exemplify the rapid change in the agent's insolation and determining if the above-mentioned equations are convergent.

Two results occur from choosing the speed reference: 1) at the cost of a slower tracking response, improved error firmness at lower levels; and 2) greater oscillations quicker tracking responsiveness at higher levels at a cost. Therefore, a balanced rate must be selected[6].

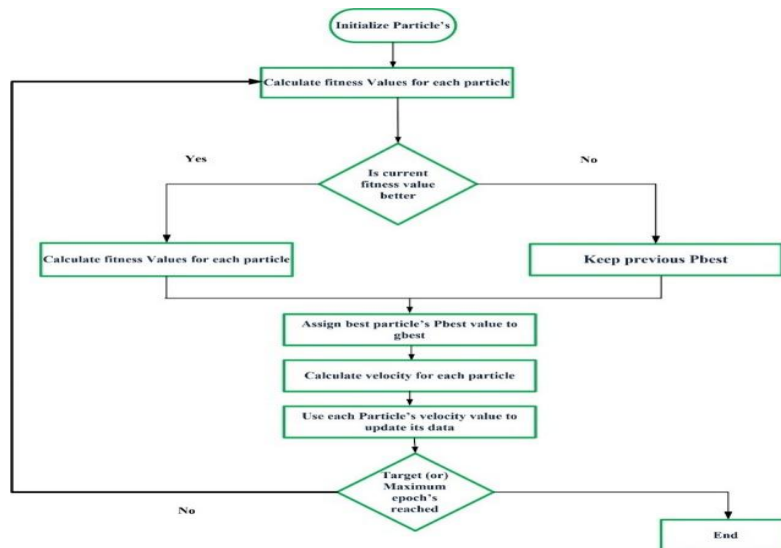

Figure 4: PSO Technique Flowchart.

Step 1: Voltage error is selected as the fitness value assessment function, and the estimated error of the recommended VSI Converter's UPQC dc link voltage is provided as the particle position.

Step2: The second phase is initializing PSO particles. PSO particles are randomly initialized during a typical startup. The particles are initially initialized for the proposed controller at predetermined, evenly spaced places around the GP.

Step 3: Once the digital controller sends the PWM instruction in time with the gate signal, assess your degree of fitness, particle i's fitness will be determined, which also acts as a representation of the particle's position.

Step 4: Identifying one's own and overall optimal fitness is step four. The global best fitness (gbest) and the newly determined individual best fitness (Pbest) of each particle value.

Simulation Results:

The experiment is set up in MATLAB/SIMULINK in accordance with the circuit depicted in figure 1.

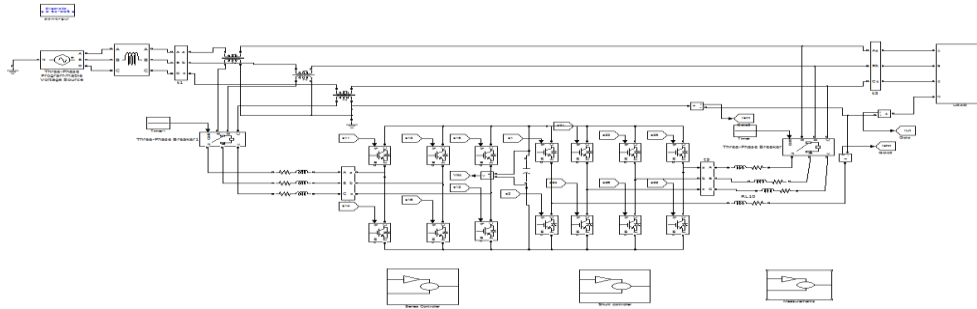

Figure 5: 3P4W UPQC system simulation diagram

Figure 6 displays the simulation results for the grid current, the statcom injected current, and the load current affected by non-linear loads. Figure 7

illustrates the total harmonic distortions for the load voltage using traditional PI, which is 3.88%.

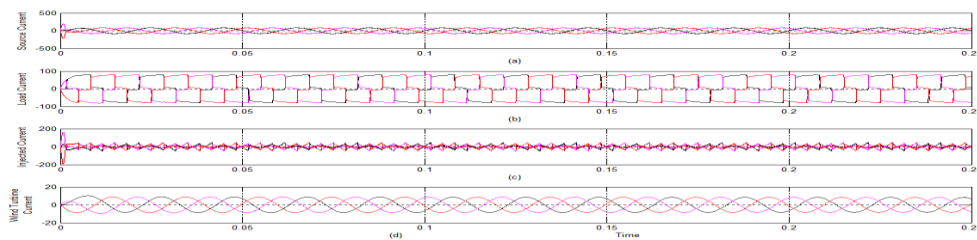
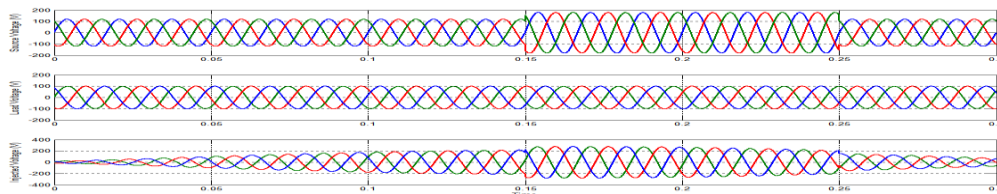

Figure 5 displays the results of the simulation for grid current, load current, and inverter current.



The results of the simulation for the load voltages, the UPQC-injected voltages, and the source voltages with swell are shown in Figure 6.

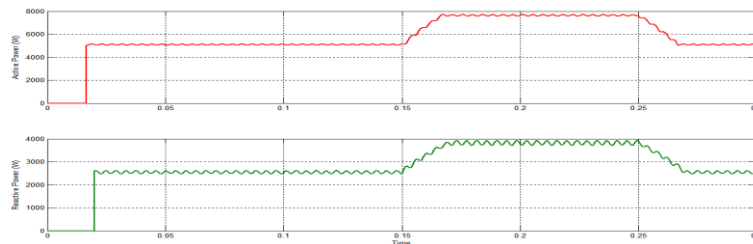

Figure 7: Simulation Result for Active and Reactive Powers.



Figure 8: Simulation Results for DC capacitor voltage.

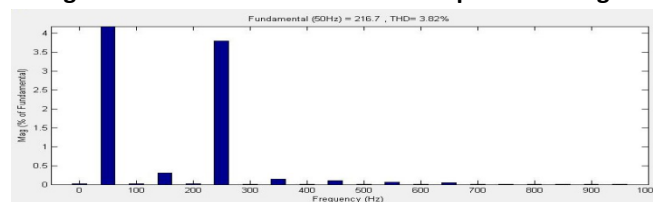

Figure 9: Source current FFT analysis with PI controller.

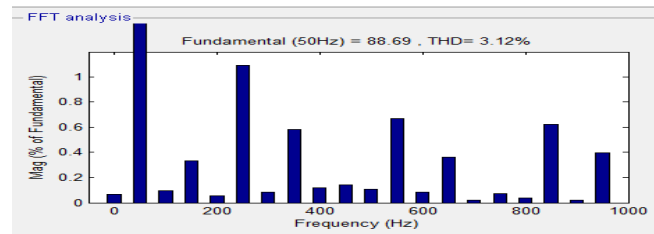

Figure 10: Source current FFT analysis with a PSO controller.

THDs of the UPQC with various controllers are shown in Table 1.

Control techniques	Total harmonic distortion (THD %)
PSO controller	3.12%
Pi controller	3.89%

Conclusion: Therefore, an all-purpose power conditioner called a 3P4W UPQC is used to reduce multiple types of voltage disturbances and stop current harmonics. By doing an experiment in MATLAB, one has noticed the unified power quality conditioner's suggested model. The simulation findings demonstrate that non-linear loads harmful effects on voltage and current may be minimized. For the purpose of creating series and shunt converter controllers, an appropriate mathematical model of the UPQC was established. The simulation results have also been detailed, proving that although compensation is carried out in both scenarios, the controller response is implemented using PI and PSO controllers, and the outcomes are contrasted between these two controllers among these.

References

- [1] Venkatesh Tadivalasa, Pabitra Kumar Biswas, Upama Das. "Controlling of PV fed BLDC Motor using FUZZY and PSO Techniques" , 2022 International Conference on Futuristic Technologies (INCOFT), 2022
- [2] A. Chandra. "A Novel Structure for ThreePhase Four-Wire Distribution System Utilizing Unified Power Quality Conditioner (UPQC)" , 2006 International Conference on Power Electronic Drives and Energy Systems, 12/2006
- [3] Karanki, Geddata, Mahesh K. Mishra, B. Kalyan Kumar. "A Modified Three-Phase FourWire UPQC Topology With Reduced DC-Link Voltage Rating" , IEEE Transactions on Industrial Electronics, 2013
- [4] K. P. Sozanski. "Three-phase harmonic compensation using the sliding DFT algorithm" , 2005 IEEE Russia Power Tech,2005.
- [5] Mehdi Forghani, Saeed Afsharnia. "Online Wavelet Transform-Based Control Strategy for UPQC Control System" , IEEE Transactions on Power Delivery, 2007
- [6] Patro, Kheeradhwa, and Alok Kumar Pradhan. "A single phase p-q theory based active filter" , 2015 International Conference on Electrical Electronics Signals Communication and Optimization (EESCO), 2015.
- [7] Khadkikar, Vinod, and Ambrish Chandra. "A Novel Structure for Three-Phase Four-Wire Distribution System Utilizing Unified Power Quality Conditioner (UPQC)" , IEEE Transactions on Industry Applications, 2009.
- [8] Ucar, Mehmet, and Sule Ozdemir. "3-Phase 4- leg unified series-parallel active filter system with ultracapacitor energy storage for unbalanced voltage sag mitigation" , International Journal of Electrical Power & Energy Systems, 2013.
- [9] Arindam Ghosh, Gerard Ledwich. "Power Quality Enhancement Using Custom Power Devices" , Springer Science and Business Media LLC, 2002