

Parallel Robot Path Planning via Dual Fractional Order Polynomial

Dheeresh Upadhyay¹, Rajesh Kumar Upadhyay², Sandeep Pandey³

^{1,2}Department of Electrical and Electronics Engineering, Mangalayatan University, Aligarh, UP, India

³Department of Electrical and Instrumentation Engineering, Thapar Institute of Engineering and Technology, Patiala
Email: dheereshupadhyay123@gmail.com, rajeshupadhyay1@gmail.com, sandeep.pandey@thapar.edu,

Abstract—A novel methodology is suggested to track the desired trajectory, which is used for delta robot. The proposed method is based on the fractional order polynomial for Cartesian space. In which, two types of fractional order polynomial has been proposed. One is partial fractional order polynomial and another is full fractional order polynomial. The new set of polynomial coefficient for fractional order polynomial is derived. Further, Simulink model has been developed to validate the applicability of proposed method. The position, velocity and acceleration profile has been plotted and compared for step input and sinusoidal input.

Keywords—Delta robot, Cartesian space, Fractional order polynomial.

I. INTRODUCTION

A specific robot developed for manufacturing industries with more than three degrees of freedom is called delta or parallel robots. Delta robot has six degrees of freedom in which it utilizes three basic axes in the x, y and z plane along with three additional movements as pitch, roll and yaw movements. This robot is also known as the parallel robot because of its specific construction, which provides tremendous flexibility of operation in manufacturing and other industries. This robot firstly came into existence for the chocolate maker industry and professor Raymond Claval has developed a delta robot for pick and place application. The precision requirements of the parallel robot are very high to do the specific task in the workplace. In the construction of the delta robot, multiple parallel links are connected with the base from one end and the second end of these multiple links are connected with an end-effector. The control of the delta robot needs the correct information about the motion of their arms through forward dynamics and inverse dynamics analysis[1]. In recent years, many researchers are interested in developing kinematics theory of various versions of delta robots for different applications[2][3][4]. Another important task for the smooth operation of the robot is path planning and according to the polynomial theory, numerous methods have been proposed[5][6][7]. The cartesian polynomial scheme and joint polynomial scheme of delta robots have been discussed in [8]. In which integer-order polynomial expression and their coefficient value for trajectory tracking were derived. As an emerging area of research in the various field of engineering and other fields, fractional-order calculus came with their significant advantages. In this paper, an attempt has been made to develop a fractional-order polynomial scheme for path planning of delta robot. The position, velocity and acceleration of the arm of the delta robot have been studied under the umbrella of fractional order polynomial. The simulation model of the delta robot has been developed first in the MATLAB environment for this purpose. The prototype of the delta robot developed by Acrome has been used for

creating the Simulink empowerment. In the next step, the outcome of the proposed method has been compared with the related existing integer order method. Simulation results shows the effectiveness of fractional polynomial in cartesian space by comparing the different parameters during operation of delta robot.

II. DELTA ROBOT CONSTRUCTION AND DYNAMICS

In the construction of the delta robot, multiple parallel links are connected with the base from one end and the second end of these various links are associated with an end-effector. It makes an assembly to form a parallelogram and provides rotation flexibility in addition to the three basic movements in the x, y and z-direction. In normal robots, the rotation movement is restricted, making the delta robot a better alternative for fast and flexible operations. The base of delta robot is connected to a firm surface near or above the working area and all the driving actuators are mounted on the base as shown in figure.1. The multiple flexible links can be made lighter with respect to the base because they don't carry any actuators, provide a low moment of inertia, and give flexibility of the fast movement of the robotic arm. Another end of the arm is ended with an end-effector used to hold the object.

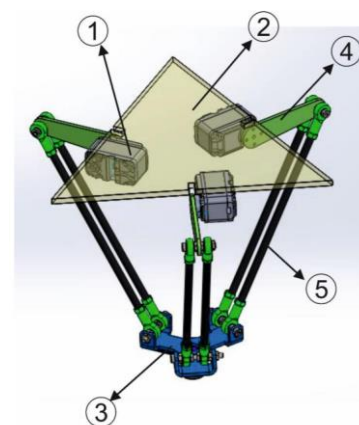

Fig. 1. The General Mechanical Structure of delta robot:
1. Smart Servo Motor 2. The base Plate 3. The

Travelling End-effector Plate 4. The Upper Arm 5.
The Lower Arm

The ACROME Delta Robot comprises three identical arms in parallel between the base plate and the traveling end-effector plate. Combining the constrained motion of these arms results in 3 translational degrees of freedom. The upper robot arms are directly attached to the actuators. The three actuators are rigidly mounted on the base plate with 120° in between. Each of the lower arms has two parallel bars. It connects the upper arm with the traveling end-effector plate. The system was integrated with a round electromagnet and an USB camera for pick and place applications.

(a) Forward Kinematics

In this section, the analysis of the kinematics of Delta Robot presents solutions in two forms: Forward and inverse kinematics. Delta Robot mechanism's kinematics analysis is simply the study of mapping between the cartesian space and joint space. Mapping from the joint space to Cartesian space is called forward kinematics, while the mapping from cartesian space to joint space is called inverse kinematics, as shown in figure.2.

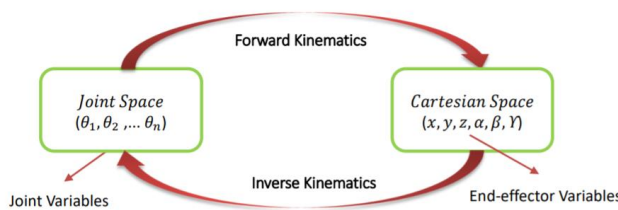

Fig. 2. Relations between forward and Inverse Kinematics

As the forward kinematics is shortly described above, the three joint angles ($\theta_1, \theta_2, \theta_3$) are inputs and the Cartesian coordinates (x, y, z) are the outputs forward kinematics as shown in figure.3. Joint angles are applied to servo motors and the corresponding Cartesian coordinates are calculated via forwarding kinematics equations.

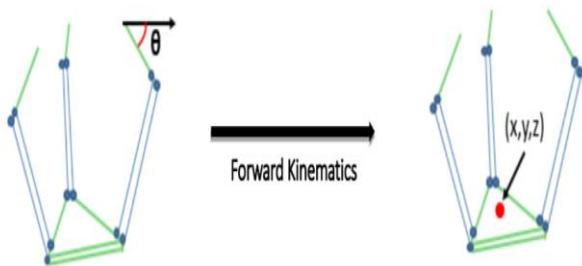

Fig. 3. Mapping from Joint Space to Cartesian Space

To construct the forward kinematics of the Delta Robot, let's first designate the physical parameters of the robot below in table I.

Table I. Parameters nomenclature of delta robot

f	Side of the base plate triangle
e	Side of the traveling plate triangle
r_f	Length of the upper arm
r_e	Length of the lower arm

A reference will be chosen at the center of the base triangle so the z-coordinate of the end-effector will always be negative. It is useful for choosing the unique and correct solution in the forward kinematics solution set.

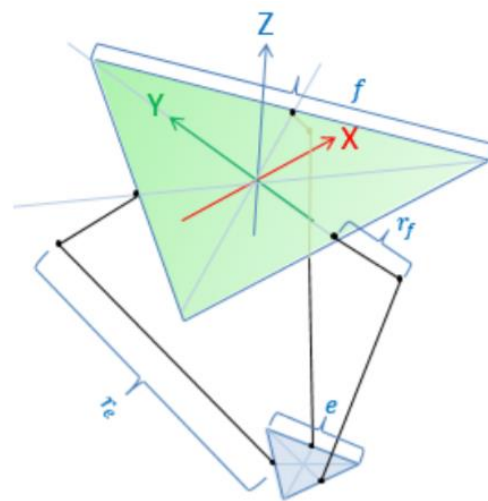

Fig. 4. Delta Robot Schematics

The forward kinematics equations for delta robot are described as given in (1) and (2)[9]

$$x = \frac{a_1 z + b_1}{d} \quad (1)$$

$$y = \frac{a_2 z + b_2}{d} \quad (2)$$

Where the denominator parameter is defined in (3)

$$d = x_3(y_2 - y_1) - x_2(y_3 - y_1) \quad (3)$$

Finally, the value of different parameters a_1, b_1, a_2, b_2 are given in (4),(5),(6) and (7)

$$a_1 = (z_1 - z_2)(y_3 - y_1) - (z_3 - z_1)(y_2 - y_1) \quad (4)$$

$$b_1 = -0.5[(w_2 - w_1)(y_3 - y_1) - (w_3 - w_1)(y_2 - y_1)] \quad (5)$$

$$a_2 = (z_2 - z_1)x_3 - (z_3 - z_1)x_2 \quad (6)$$

$$b_2 = 0.5[(w_2 - w_1)x_3 - (w_3 - w_1)x_2] \quad (7)$$

As mentioned before, one can choose the negative z solution because the origin point is located on the base plate. Therefore, the downward direction has a negative sign. The negative solution for z is given in (8)

$$z = \frac{-b + \sqrt{\Delta}}{2a} \quad (8)$$

To complete the forward kinematics solution of the Delta Robot, we substitute z from (8) into (1) and (2). Finally, the solution is shown in (9)

$$\{x \ y \ z\}^T \quad (9)$$

(b) Inverse Kinematics

To know the desired position of the end-effector, it is compulsory to determine the angle of each joint to set motors in the proper position for picking. This process is known as inverse kinematics. The following section explains the inverse kinematic solutions for the Delta Robot and the mathematical equations. The schematic presentation of inverse dynamics of the Delta robot is shown in figure.5.

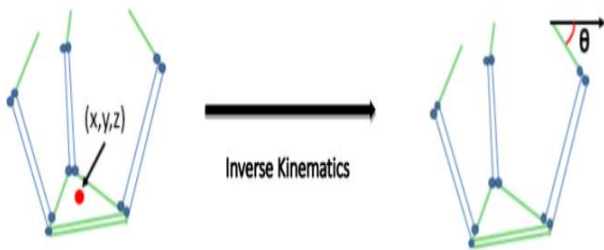

Fig. 5. Mapping from Cartesian Space to Joint Space

To construct the inverse kinematics of the delta robot, let's return to figure 4 and remember the Delta Robot's physical parameters. Like the forward kinematics section of the Delta Robot. The inverse kinematics solution for the first joint is given in (10)[9]

$$\theta_2 = \arctan \left(\frac{z_{J1}}{y_{F1} - y_{J1}} \right) \quad (10)$$

For remaining angles θ_2, θ_3 , let's rotate the coordinate system in the XY plane around the z-axis by 120 and -120 degrees and the final solution is given in (11) and (12)

$$x' = x \cos \left(\frac{2\pi}{3} \right) + y \sin \left(\frac{2\pi}{3} \right) \quad (11)$$

$$y' = y \cos \left(\frac{2\pi}{3} \right) - x \sin \left(\frac{2\pi}{3} \right) \quad (12)$$

Which gives the final form of inverse kinematics as shown below in (13)

$$E_0(x, y, z) \quad (13)$$

III. PATH PLANNING OF DELTA ROBOT

In general, a trajectory or path describes the desired motion of a manipulator in a multidimensional space. In robotics, trajectory defines as a time history of the position, velocity, and acceleration for each degree of freedom. Here, the basic problem is trajectory generation which refers to designing the trajectory in joint space from the initial point to the final point.

Trajectory generation occurs at run time; position, velocity, and acceleration are computed in the most general case. These trajectories are computed on computers in discrete-time so the trajectory points are calculated at a specific rate, called the path-update rate

In Cartesian space, path generation is described in terms of x, y and z coordinates functions. The joint angles are repeatedly calculated through inverse kinematics equations of the Delta Robot. The Cartesian reference frame of the Delta Robot is the center of the base plate triangle. Therefore, Cartesian space trajectories move relative to this reference frame.

Each axis moves independently, so there are three trajectories for the Delta Robot. There are advantages to Cartesian space schemes. The motion between the initial and final points is known at each instant and is controllable. The motion is also visual, so it is easy to describe. Many smooth functions are different than each other between two points. They are shown in Figure 6.

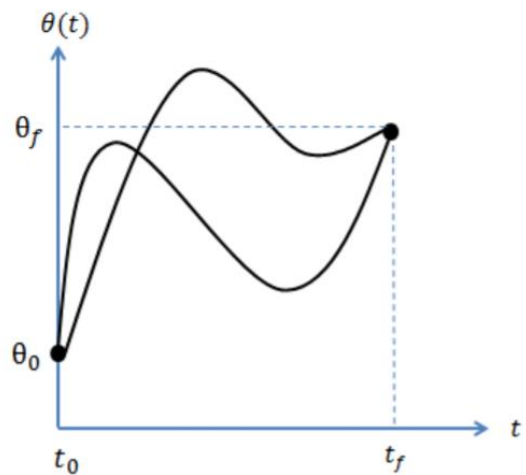

Fig. 6. Possible Path Shapes for a Single Joint

To obtain a fractional order polynomial, four constraints are needed. The initial and the goal position of the manipulator are two constraints:

$$\theta(0) = \theta_0$$

and

$$\theta(t_f) = \theta_f$$

The other constraints come from velocity. The final and the initial velocities have to be zero, so our desired trajectory has to satisfy the following constraints:

$$\dot{\theta}(0) = 0$$

and

$$\dot{\theta}(t_f) = 0$$

To satisfy the above constrain, the trajectory function's order must be an integer or fractional order polynomial function. While in literature, third order polynomial was also used to do the specific task. In the proposed work, two trial has been carried out with partial fractional-order and full fractional-order polynomial. These four constraints are used for solving four unknown coefficients of the function. In the first trial, the partial fractional-order polynomial has the following form and position, velocity and acceleration is given in (14), (15) and (16), respectively

First trial

$$\theta(t) = a_0 + a_1 t + a_2 t^2 + a_3 t^{3.5} \quad (14)$$

$$\dot{\theta}(t) = a_1 + 2a_2 t + 3.5a_3 t^{2.5} \quad (15)$$

$$\ddot{\theta}(t) = 2a_2 + 8.75a_3 t^{1.5} \quad (16)$$

When four constraints are applied to the (14) and (15), one can obtain the coefficient value as given below

$$a_0 = \theta_0$$

$$a_1 = 0$$

$$a_2 = \frac{7}{3t_f^2}(\theta_f - \theta_0)$$

$$a_3 = -\frac{2}{1.5t_f^{3.5}}(\theta_f - \theta_0)$$

The first simulation model for trajectory generation using partially fractional-order polynomial in cartesian space has been developed with the information given above.

Second trial

In the second trial, the full fractional-order polynomial has the following form and position, velocity and acceleration is given in (17), (18) and (19), respectively

$$\theta(t) = a_0 + a_1 t^{1.5} + a_2 t^{2.5} + a_3 t^{3.5} \quad (17)$$

$$\dot{\theta}(t) = 1.5a_1 + 2.5a_2 t^{1.5} + 3.5a_3 t^{2.5} \quad (18)$$

$$\ddot{\theta}(t) = 3.75a_2 t + 8.75a_3 t^{1.5} \quad (19)$$

When four constraints are applied to the (17) and (18), one can obtain the coefficient value as given below

$$a_0 = \theta_0$$

$$a_1 = 0$$

$$a_2 = \frac{7}{2t_f^{2.5}}(\theta_f - \theta_0)$$

$$a_3 = -\frac{5}{2t_f^{3.5}}(\theta_f - \theta_0)$$

The second simulation model for trajectory generation using partially fractional-order polynomial in cartesian space has been developed with the information given above.

IV. SIMULATION RESULTS

To simulate the path tracking, one Matlab simulation model has been developed. The same model has been used to validate the applicability of the proposed method. This model used two s-function blocks to define the desired fractional-order polynomial. The computation of the coefficient of the fractional polynomial is carried out through the derived equation as done in the above section.

In the first attempt, the initial position was defined from the origin and the final position was kept on 40, which was one kind of step signal as shown in figure.7. Integer order polynomial developed in [9] were used to take the first result. The remaining two results have been taken based on the partially fractional-order polynomial and entire fractional-order polynomial. These two polynomial coefficients show the significant difference from the integer order polynomial. All three polynomial acquired different paths to follow the same final position from the same initial position.

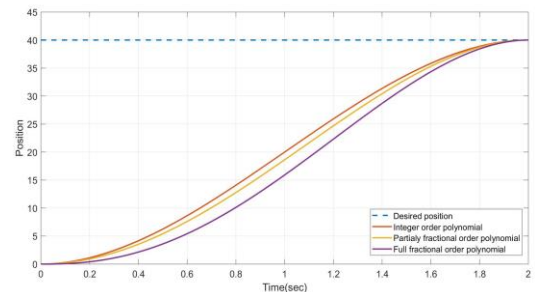

Fig. 7. Position profile comparison of different polynomial schemes for step trajectory.

To understand the velocity and acceleration profile behavior, two separate results have been taken from the simulation model. One is for the velocity shown in figure.8, and another is for acceleration which is shown in figure.9. The entire fractional-order polynomial shows the highest pickup in the velocity profile and the lowest dip in the acceleration profile.

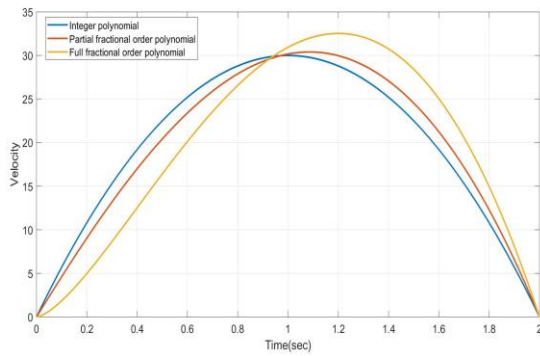

Fig. 8. Velocity profile comparison of different polynomial scheme step trajectory.

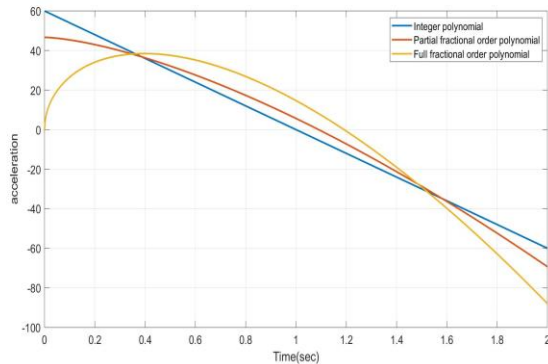

Fig. 9. Acceleration profile comparison of different polynomial scheme step trajectories.

Another attempt has been made to follow the sinusoidal trajectory and the same simulation model. Figure.10 shows the trajectory tracking of all three different polynomials. In which full fractional-order polynomial acquire the lowest undershoot and overshoot during the tracking operation of the same sinusoidal path.

The other two profile for the same signal is shown in figure.11 and figure.12, which shows the velocity and acceleration, respectively. All three cases have different profiles during the path tracking operation, and full fractional-order polynomial renders the fast operation and improved acceleration profile.

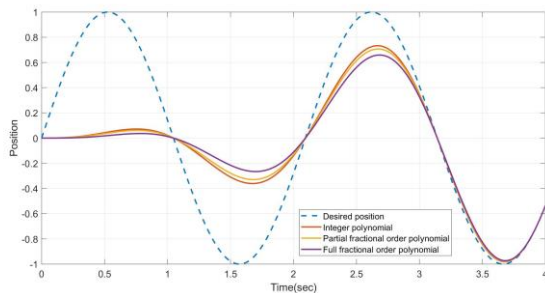

Fig. 10. Position profile comparison of different polynomial schemes for sinusoidal trajectory.

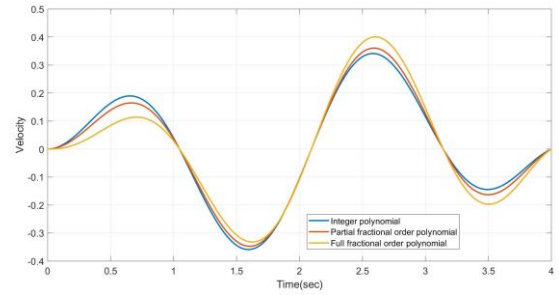

Fig. 11. Position profile comparison of different polynomial schemes for sinusoidal trajectory.

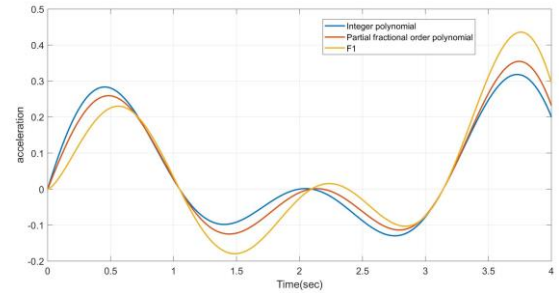

Fig. 12. Position profile comparison of different polynomial schemes for sinusoidal trajectory.

V. CONCLUSIONS

The proposed method improves the velocity and acceleration profile for different inputs tracking used by the delta robot. The method uses two trials of fractional order polynomial. The new set of coefficients for fractional order polynomial were used to develop new simulation model along with parameters values of delta robot. In addition to this two main inputs were employed to the developed model. One is step input and another is sinusoidal trajectory. The novel fractional order polynomial method in Cartesian space shows the faithful tracking of both the signal and shows the applicability of proposed method.

REFERENCES

- [1] J. Wang, and X-J Liu, "Analysis of a novel cylindrical 3-DoF parallel robot", Robotics and Autonomous Systems Vol. 42, 1, pp. 31-46, 2003.
- [2] Pande, S.D., Gudipalli, A., Joshi, R., Chaudhari, S., Dhabliya, D., Ahammad, S.K.H., Kale, S.D. A Fuzzy-Based Slip Resistive Controller for Front Wheel Drive Autonomous Electric Vehicle (2023) Electric Power Components and Systems, .
- [3] Y. L. Kuo, "Mathematical modeling and analysis of the Delta robot with flexible links," Computers and Mathematics with Applications Vol. 71, pp. 1973-1989, 2016.
- [4] V. Angel and J. Viola, "Fractional order PID for tracking control of a parallel robotic manipulator type delta," ISA Transactions, Vol 79, pp.172-188., 2018

- [5] Y.L. Kuo, and P.Y. Huang, P-Y, "Experimental and simulation studies of motion control of a Delta robot using a model-based approach," *International Journal of Advanced Robotic Systems*, pp 1-14, 2017.
- [6] G. Ecorchard, and P.Maurine, "Self-Calibration of Delta Parallel Robots with Elastic Deformation Compensation," *Intelligent Robots and Systems.*, pp. 462-467, 2005.
- [7] V.Poppeova, J. Uricek, V. Bulej, and P. Sindler, P,"Delta robots – robots for high speed manipulation," *Technical Gazette Vol.18*, pp. 435-445, 2011.
- [8] J. Brinker, B. Corves, and Y. Takeda, Y., "Kinematic performance evaluation of high-speed Delta parallel robots based on motion/force transmission indices," *Mechanism and Machine Theory Vol.15*, pp. 111–125, 2018.
- [9] Pandey, J.K., Veeraiah, V., Talukdar, S.B., Talukdar, V., Rathod, V.M., Dhabliya, D. Smart city approaches using machine learning and the IoT (2023) *Handbook of Research on Data-Driven Mathematical Modeling in Smart Cities*, pp. 345-362
- [10] V. Damic, M. Cohodar, and A. Voloder, "Modelling and Path Planning of Delta Parallel Robot in Virtual Environment," *Proceedings of the 29th DAAAM International Symposium, DAAAM International, Vienna, Austria*, pp.0149-0156, 2019.
- [11] A. Olsson, "Modeling and control of a Delta-3 robot, master thesis," *Department of Automatic Control, Lund University February 2009*.
- [12] Juneja, V., Singh, S., Jain, V., Pandey, K.K., Dhabliya, D., Gupta, A., Pandey, D. Optimization-based data science for an IoT service applicable in smart cities (2023) *Handbook of Research on Data-Driven Mathematical Modeling in Smart Cities*, pp. 300-321.