

Predictive Integration of Renewable Energy Sources into Microgrid Management System

Sunila S,

Assistant Professor,
Department of Electrical and Electronics Engineering,
APJ Abdul Kalam Technological University, sunilaarshid@gmail.com

Dr. J Ravikumar,

Assistant Professor, Saveetha University,
raviram03@gmail.com

Mr. Yokesh V,

Assistant Professor,
Department of ECE, Sri Venkateswara College of Engineering,
yokesh.inba@gmail.com

Abstract— A smart grid allows for the extension of current power transmission and distribution by integrating energy, control, and communication. Microgrids are a crucial component of smart grid collaboration. Power processing allows power electronic devices and systems to be placed physically close to the weights and actuators. There is difficulty in creating a model that is at once dynamic, buoyant, and sustainable. In this study, we present a novel modelling and control prototype that facilitates the smart grid's incorporation of Microgrids based on renewable energy sources. The Microgrid's architecture allows for more renewable energy sources to be integrated into it. To illustrate state transitions in Microgrid and total power conditioning with transient response, the proposed model is experimented with on the MATLAB/ Simulink platform.

Keywords: *Smart Grid, dynamic, predictive model, Microgrid.*

1. OUTLINE

An updated electrical grid makes use of a wide variety of new power plants. The consolidation of various assets into the main current to boost productivity, ensure consistency, and cut costs [1]. Blocks like solar panels, wind turbines, fuel cells, and the like make up this system. Microgrid is a highly innovative system for linking these assets. Electronic interfaces and devices, data transmission, and control systems for power plants are all benefiting from technological progress. Distribution and storage of electrical power rely heavily on renewable energy sources and systems (RESS) including biomass, biogas, geothermal, etc. Remote power and green initiatives, such as Microgrids, can save money because to the concept of resilient energy infrastructure [3, 4]. Integration of small, co-located Microgrids with renewable energy resources into the current conventional Grid is fraught with difficulties in power quality restoration [4].

Microgrids are based on distributed generation, which reduces environmental consequences and increases supply security. Developing such a model based on state-of-the-art research methods in the field of Microgrid was crucial to the long-term viability of a sophisticated hybrid power generating, distribution, and storage system. The smart grid paradigm subsists established on the use of information and communication technologies (ICT) to gather data and activate all operations that boost reliability, power quality, and sustainability in energy generation [5]. Because of the need for urban services, improvements have been made to the infrastructure supporting energy and information transmission. Utilities rely on a variety of IT systems to guarantee the Microgrid's continuous operation and high standard of performance. As the demand for electricity rises in urban areas, renewable sources are increasingly being used to supply the Microgrid. Voltage and power fluctuations, along with other serious issues, are a result of the continual, decentralized development of renewable energy infrastructure. Microgrids implement the smart grid concept through decentralized power generation and real-time optimization of energy use [7]. The technological implications of Microgrid, which include the integration of renewable resources into the grid, are crucial to the progress of smart cities.

In addition to the primary energy sources, the Microgrid based system also makes use of a wide variety of sources at the watt and kW level for power generation and distribution. In either grid-synchronized or isolated modes, microgrids then distributed generation carry out the relevant operations. Several operational combinations can be constructed, each with its own determined efficiency and cost-effectiveness, to provide an uninterruptible supply to the loads from the sources. Modelling such a system will be difficult due to the broad diversity of sensible components and the decentralized transmission between the units, as well as the inherent

instability of RES and transitory power quality problems [8]. In this study, we offer a hybrid modelling strategy for managing smart grid based Microgrids across a range of operational states. The suggested system's transient response was verified by simulating a fault in the Microgrid. The suggested system is tested with a three-phase fault, and variation in reactive power and harmonics are tracked with usage of a smart controller. The next section explains the Microgrid system proposal, then there's an examination of experiments to see how well the system works, and lastly there's a summary.

2. PROPOSED LAYOUT

The brains of a smart Microgrid are the controllers they use to keep the whole thing running smoothly. Figure 2.1 depicts a sophisticated Microgrid system with added intelligence. The following diagram depicts a smart grid model that includes a microgrid powered by renewable energy sources, along with the standard components used in such a system.

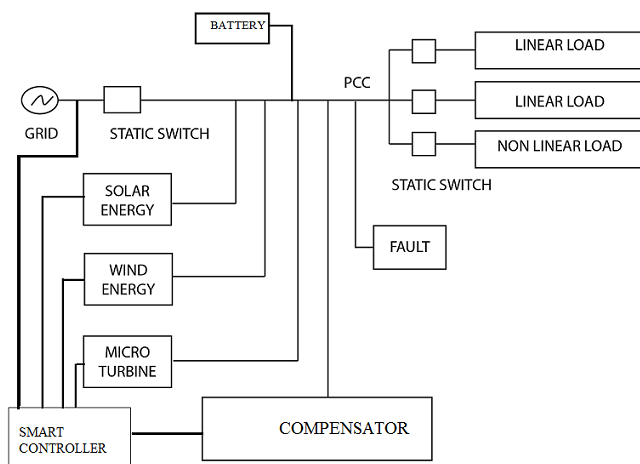

Fig.2.1. Smart controller within Microgrid.

An exceptional smart controller is used to methodically manage the primary utility grid, which takes the shape of a huge generator and its excitation system and control. This is how primary power is transmitted via the grid. Power electronic converters and interfaces are used to connect renewable energy sources to the AC load bus, which might be static or dynamic. The supervisory control technique of Microgrid smart central controller [MSCC] ensures that the power supply is maintained even when dynamic operations are taking place. Whether or not the primary grid side or transmission lines are operational, power can always be supplied through RES in an MSCC because of the switching that takes place with the help of the Predictive technique. Microgrids can continue to operate in sync with the main grid even in highly variable environments. Illustration 2.1 illustrates how a decentralized power supply can Microgrids are made up of many power sources, an inverter or converter to convert voltage, and a coupling device before link that allows microgrid to communicate with the main power grid. Each component of the toolkit can be used with the Simpower

or MATLAB/Simulink platforms. These libraries can be used for the analysis and modelling of any part of the system[13-14].

Modern technology has the potential to solve the problems associated with Static switching, which is used to connect renewable energy sources to the main grid. Microgrids are decentralized electrical power networks that are connected in some way to the larger, more traditional grid [9]. The proposed system can make use of methods such cyber physical design to boost the smart grid's robustness, efficiency, and transient response [10, 12]. Using a dynamic matrix control architecture, the model predictive technique will regulate several electrical factors in addition to dispersed besides hybrid power sources and their combinations. In response to power demands and surpluses that can be emptied into storage, MSCC enables the Microgrid to automatically incorporate the most cost-effective power sources, or efficient and dependable combinations. Subsections detail the assimilation's necessary parts:

A. Micro- sources

Micro-sources, short for "micro-generation," are small power generators that can be connected to the microgrid's main ac bus with the use of converters. Microgeneration is a common application of renewable energy sources. The benefits of wind, solar, and Micro turbines include high efficiency, little pollution, and adaptability. Microgrids equipped with these accoutrements make for a robust hybrid energy system [12]. The Simpower systems tool box includes a model for both wind and solar that can be used as micro-sources, as ensured in Figures 2.3 and 2.4.

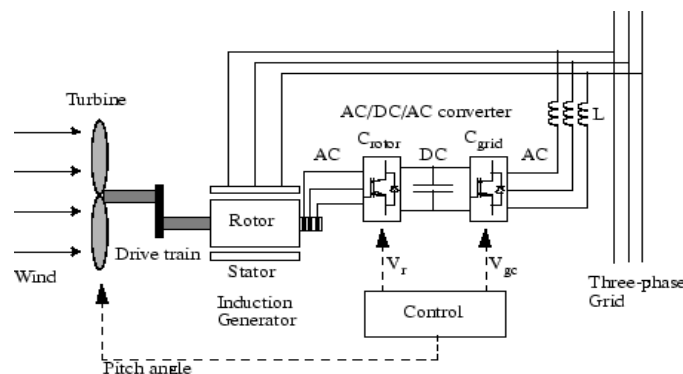

Microgrid Wind Model (Figure 2.2)

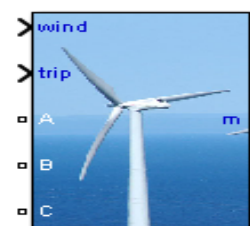

Wind MATLAB Model, Fig. 2.3

The accompanying picture shows how MATLAB's implementation of the wind turbine model in MATLAB/Simulink 2019a can be used as a micro-source.

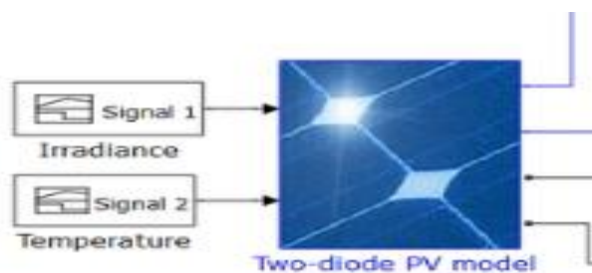

Figures 2-4: A MATLAB simulation of the sun

Incorporation hooked on the Microgrid and the primary grid will make use of the solar and wind forecasting model. As indicated below, model prediction techniques can be used to synchronize the microgrid's resources with the main grid once renewable energy has been integrated into the system[15].

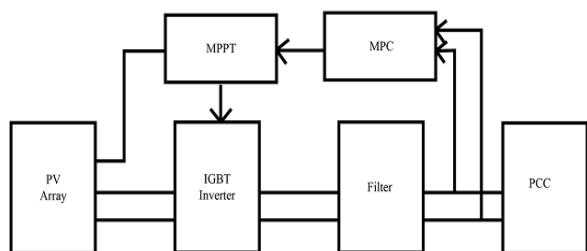

Model for predicting solar energy output (Figure 2.5) Microturbine predictive model[16], employed in MSCC's smart microgrid integration using predictive approaches, is shown in figure 2.6.

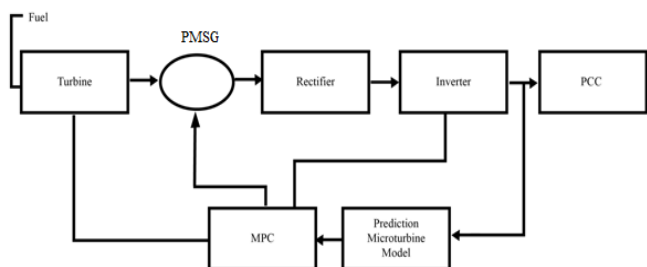

Microturbine schematic shown in Fig. 2.6

Attractive forms of bundles that can be used in a Microgrid are parameterized from implementations of solar cells, wind turbines, and microhydel turbines.

B. Voltage Source Inverter

The inverter enters the picture when the time comes to link micro-source to the primary ac load bus. With the help of the right control mechanism and pulses from the Microgrid's intelligent central controller, the modelled RES may be connected to the Grid. Microgrids can function either in sync with the larger grid or independently, the MSCC, which is modelled using a predictive technique, facilitates the

connection of dispersed generators to the load bus. Each VSI model has its own DG source, inverter, and filter set up to generate a pure sine wave at the output, as well as a predictive controller. Figure 2.7 shows how the MATLAB platform may be used to create a predictive model with VSI for solar cells/PV arrays, wind turbines, and microturbines.

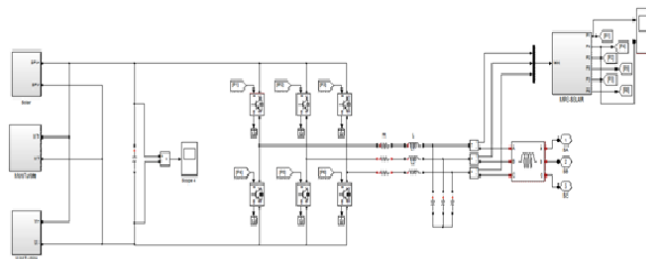

Figure 2.7. Predictive VSI model

All of the DGs' VSI-integrated models are displayed in the preceding figure. This novel and economical model works well because non-linear loads are present in the Microgrid, which is especially true when the grid is operating in an isolated mode. The predictive strategy used to model the smart controller also provides the most reliable method for regulating the Microgrid. At any given time, the Microgrid system's harmonic content is calculated using the modulation method.

The voltage mode is controlled by a model predictive controller, which varies the square wave's duty cycle. PWM inverters based on thyristor (IGBT) technology are used to reduce damage and improve performance. For the inverter's output to be consistent, filters with three phases of LPF are typically used. Predictive technique reference frames can be used to build a feedback loop. Gate pulses are created by power devices in the VSI and used to keep tabs on the demands for control. To get rid of harmonics and correct reactive power, special power devices are inserted into the PCC to inject compensating currents and voltages. The primary load bus is where VSI is often integrated using an interconnection transformer. Energy-saving and high-quality power implementation devices for DGs have been selected [7].

C. Interface Design

At a central coupling point, coupling inductors connect the DGs to the main grid and the loads. With Simpower Systems, you may plan for a three-phase balanced load with an RLC series combination. The impedance of the load block remains constant throughout the chosen frequency range. Using a predictive method, the transformers next to PCC couple CPD-style distribution static compensators. Whether by static switches or inductors, loads are wired into the load bus. At individual point of PCC, filters are employed to smooth down the output from each inverter; the type of filter used depends on the type of compensator. In isolated mode, MSCC must independently regulate the microgrid by producing reference voltages for effective connection to the load bus.

3. SYSTEM INTEGRATION AND CONTROL

Adding one of these advanced sources into the control system design won't interfere with the functioning of the Microgrid. DGs' ability to autonomously manage frequency and power allows them to respond more quickly and smoothly to fluctuations in load demand. Without the need for programmed information, DGs must automatically respond to changes in the Microgrid system. Smart grid connectivity is not possible with the standard unity power factor controllers. Due to DG integration, local voltage and frequency controllers are unable to regulate fluctuations. By taking the appropriate measures, zero current has been circulating within the Sources to ensure local stability and reliability.

Each micro-source's active and reactive power both change as the inverter's output voltage rises and falls. Realization of both active and reactive power at the PCC is possible through

$$P = \frac{3EV \sin \delta}{\omega L} \quad (1)$$

$$Q = \frac{3V \{E \cos(\delta) - V\}}{\omega L} \quad (2)$$

Wherever V and E are the grid and inverter voltages, respectively, at their respective outputs. Inductive reactance is measured in units of "L." Modulating both amplitude and phase using VSI Consequently

$$P = \frac{EV \sin \delta}{X} \quad (4)$$

$$Q = \frac{V \{E \cos(\delta) - V\}}{X} \quad (5)$$

The observed inductor reactance X, in conjunction with the system voltage V, can be used to calculate the real and reactive power flows.

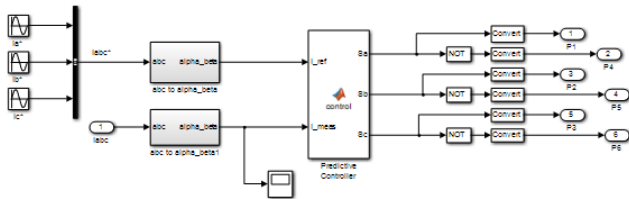

Smart grid predictive model, shown in Figure 3.1

In following diagram, we see MPC's typical linear structure. Reference changes control signals are now being regulated by MPC. Integrating NL predictive control into linear MPC is feasible, and the combined system performs reliably in standalone mode. After compensating for the measured currents and voltages, the predictive model will extract power. The prediction horizon method takes in a reference signal,

transforms it into an alpha-beta form, and then uses that form to generate compensatory currents and voltages, which are then delivered to the point of common coupling. From V0 through V7 are considered, with both 0 and 1 being the starting and ending states, respectively. The RH approach uses the following states:

$$V_1 = \frac{2}{3} * V_{dc} \text{ -----} \quad (3.6)$$

$$V_2 = \frac{1}{3} * V_{dc} + 1j * \frac{\sqrt{3}}{3} * V_{dc} \text{ ----} \quad (3.7)$$

$$V_3 = -\frac{1}{3} * V_{dc} + 1j * \frac{\sqrt{3}}{3} * V_{dc} \text{ -----} \quad (3.8)$$

$$V_4 = -\frac{2}{3} * V_{dc} \text{-----} \quad (3.9)$$

$$V_5 = -\frac{1}{3} * V_{dc} + 1j * \frac{\sqrt{3}}{3} * V_{dc} \text{-----} \quad (3.10)$$

$$V_6 = \frac{1}{3} * V_{dc} + 1j * \frac{\sqrt{3}}{3} * V_{dc} \text{-----} \quad (3.11)$$

V2, V3, and V5, and V6 are complex conjugates of the dc voltage measurements, as are V1 and V4 from the state equations. The matrix formed by these states is as shown below.

$$V = [V_0, V_1, V_2, V_3, V_4, V_5, V_6, V_7]$$

Subsequent criterion is specified by the equation and considers the values of the reference current at the sampling time K, which is now.

$$i_{kref} = I_{ref(1)} + 1j * I_{ref(2)}$$

At each sample interval of length K, the current values are recorded, plus the current state at the Kth time is calculated using the formula,

$$i_k = I_mean(1) + 1j * I_mean(2)$$

Nevertheless the estimation of back emf is governed by the formula

$$e = \left[V(x_{old}) - \frac{L}{T_s} * i_k - \left(R - \frac{L}{T_s} \right) * i_{old} \right]$$

$$[x_{old} = 1 \ \& \ i_{old} = (0 + j0)]$$

For the next cycle, we'll use the measured current value.

$$i_{old} = i_k [\text{present state}]$$

I can take on any value between zero and k plus one, and $V_{01} = V(i)$. The equation gives a prediction for the current at time k plus one,

$$i_{k1} = \left(1 - R * \frac{T_s}{L} \right) * i_k + \frac{T_s}{L(V_{01} - e)}$$

In this expression, E represents the emf function that was determined beforehand, and V_{01} is the voltage at the next state.

The CF of the device or system being dominated by the following equation,

$$G = \text{abs}(\text{real}(i_{k_{\text{ref}}} - i_{k1})) + \text{abs}(\text{img}(i_{k_{\text{ref}}} - i_{k1}))$$

Specifically, the absolute value is denoted by abs, and it is calculated by adding real and imaginary parts of the reference and measured values. The CF is represented by the equation below, and it is dependent on the limitations or disturbances such as faults, harmonics, sag, or swells.

$$g < g_{\text{opt}}$$

$$g_{\text{opt}} = g$$

$$x_{\text{opt}} = i$$

As a result of solving the equations below, the optimal value has been saved in X_old, and the optimal switching states have been chosen.

$$S_a = \text{state}(x_{\text{opt}}, 1)$$

$$S_b = \text{state}(x_{\text{opt}}, 2)$$

$$S_c = \text{state}(x_{\text{opt}}, 3)$$

The inverters receive switching state pulsates at the gate terminal based on the expected optimal value. The intelligent controller controls the incoming and outgoing power flows in the Microgrid using a predictive technique.

Loads are supplied with energy from both the primary grid and the DGs when their operations are synchronized. Microgrids can switch to island mode automatically if grid power is lost owing to IEEE 1547 events such voltage decreases, fault blackouts, etc. Predictive control is the preferred way for handling voltage and frequency fluctuations caused by such malfunctions. Feedback for frequency and voltages is implemented using the real-time values provided from the aforementioned prediction algorithm. MSCC is able to provide inverters with the correct voltage adjustment and frequency.

4. EXPERIMENTAL ANALYSIS

Combining DER with the grid allows for the incorporation of a predictive strategy based on state transitions. Each potential energy source is given a binary number between 0 and 1, with 1 indicating that it can be used to generate electricity and 0 indicating that it cannot. Consider that there are eight potential permutations when all three sources are appropriated at the same time: 000, 100, 110, 010, 011, 001,101, and 111.Each pattern stands in for a different state of power and supply in the microgrid. In binary notation, 1 indicates ON state and 0 the OFF state. An arrowhead indicates a change in status, such as from "On" to "OFF," "previous" to "current," etc. Each sequence's final digit designates the Grid, whereas the first two designate the DGs.

We need to evaluate the integration strategy considering the following examples:

Normal Operation, Example A

Under Mode 101, just one DG is used to power the load when DG1 is on, DG2 is off, and the grid is on. With the current setup, as the load demand increases, the microgrid appears to convert to full mode 111, which indicates that DG2 = ON. At the moment, power in the Microgrid comes both from the grid and the DGs. The term "grid connected" or "synchronised mode" is used to describe this setup. Think about how DG isn't as effective at providing power as wind now that load demand has dropped. In this case, Microgrid will go into 011 mode to keep things steady and reliable. To continue its integration with the grid, DG2 will continue to function normally.

Case 2: Operation in Fault Condition

When a failure occurs, the primary grid cannot supply electricity. So, turn the grid off. Take the 010 state, which has DG1 off and DG2 on. When the system needs additional juice, it goes through a DG1- On transition, changing states to 110. In this situation, both DGs are contributing to the power supply. Power from DG2 can be turned off and the system will enter state 100 when load demand drops. Therefore, the loads will be supplied with electricity from DG1. Figure 4.2 depicts this change. Figure 4.3 depicts the Microgrid's transient reaction.

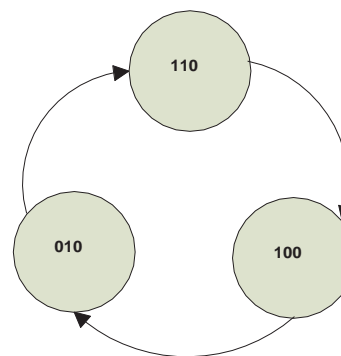
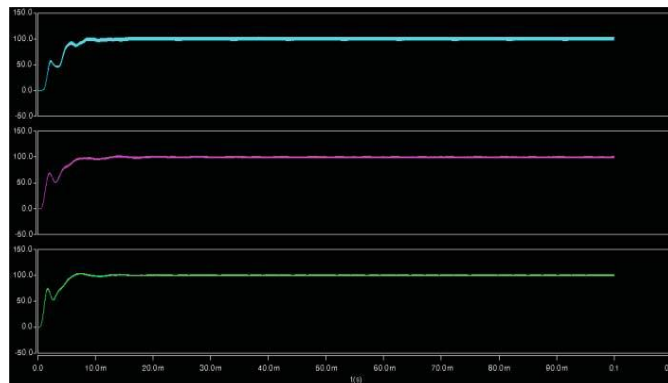

Figure 4.2. Strategy for Fault operation



Microgrid transient response to faults (Figure 4.3)

The effectiveness and efficiency of transitions determines the sorts of power sources that must supply electricity based on load requirement and power factor quality. From the

standpoint of the microgrid, communicating with the grid yields knowledge of Grid status (ON and OFF time). That determines whether there is backup power, and if so, how many sources there are. Performance in all modes of operation was analyzed, and transient situations were tested. The durations of all conceivable recoveries have been modelled. The concept of simulated time offers useful perspective when thinking about operation and switching mode in the presence of transients and demand in load. This method of predictive strategy is reliable in both normal and fault scenarios of Microgrid's smart grid operations.

5. CONCLUSION

In this study, we describe a scenario where distributed resources can be added to the Microgrid in a modular fashion through the use of a smart prediction method. Smooth Smart grid operation, even with massive renewables, is a topic of discussion. When sources, loads, and utility operators add a sensing activity, such as a predictive technique, new complications and structures emerge. For an intelligent power system to be realized, new controlling techniques must be implemented to provide high performance, low cost, and high reliability. Only by combining a Predictive based Microgrid with a smart grid would this be possible. Bringing everything together into a unified system requires substantial effort. In this study, we suggest a way for building a smart microgrid infrastructure that can take corrective action on its own.

REFERENCES

- [1] Juan W. Dixon, Gustavo Venegas and Luis A. Moran, "A series Active Power Filter based on Sinusoidal Current controlled Voltage Source Inverter", IEEE Transactions on industrial Electronics, Vol.44, No.05, pp:612-620.
- [2] T. Devaraju, V. C. Veera reddy and M. Vijay Kumar, "Modeling and Simulation of Custom power devices to Mitigate Power quality Problems", International Journal of Engineering Science and Technology, Vol.26, 2012.
- [3] Shahid A " An Overview of control architecture for next generation smart grids", 19th International Conference on intelligent System Applications to power, 2017.
- [4] Frede Blabjerg, " Power electronics –the key technology for renewable energy system integration", 4th International Conference on Renewable Energy Research and Applications, 2015.
- [5] Gu, Y, Ouyang H, " Development of Microgrid coordination and control Overview", IEEE PES innovative Smart Grid technologies, Asia, 2012.
- [6] Basu.M, Das, "Comparative Evaluation of two Models of UPQC for Suitable interface to enhance power quality", Electric Power systems Research, Vol.77, no.7, pp.821-830, 2007.
- [7] V. Khakikar and A., " A new control Philosophy for a unified Power quality conditioner to coordinate load reactive power demand between shunt and series inverters", IEEE transactions on Power delivery, vol.23, no4, pp.2522- 2534, 2008.
- [8] N.G. Hingorani and L. Gyugyi, Understanding FACTS- Concepts and Technology of flexible AC Transmission Systems, IEEE Press , New York , 2000
- [9] Shazly A. Mohammed¹, Aurelio G. Cerrada², Abdel-Moamen M.A¹, and B. Hasanin³, *Dynamic Voltage Restorer (DVR) System for Compensation of Voltage Sag, State-of-the-Art Review*, International Journal Of Computational Engineering Research(IJCER).
- [10] Kolipaka Srivani, Aiswarya rajalaxmi, REVIEW OF UPQC CONTROL TECHNIQUES FOR POWER QUALITY IMPROVEMENT, International Journal of Scientific Research Engineering & Technology (IJSRET), Volume 3 Issue 1, April 2014.
- [11] J. M. Guerrero, L. Vicuna, J. Matas, M. Castilla, and J. Miret, "A Wireless controller to enhance dynamic performance of parallel inverters in distributed generation systems", *IEEE Transactions on Power Electronics*, Vol. 19, No. 5, pp. 1205 – 1213, Sept. 2004
- [12] Miguel Casilla, Jaume Miret , Antonio Camacho , " Reduction of Current Harmonic Distortion in Three-Phase Grid-Connected Photovoltaic Inverters via Resonant Current Control", IEEE TRANSACTIONS ON INDUSTRIAL ELECTRONICS, VOL. 60, NO. 4, APRIL 2013
- [13] S. Swetha. B. Subhas, "Power Quality Improvement in Microgrid Using Active Power Conditioner" , INTERNATIONAL JOURNAL OF PROFESSIONAL ENGINEERING STUDIES Volume I/Issue I/DEC 2013.
- [14] Yunwei Li, D. Mahinda Vilathgamuwa, Poh Chiang Loh, "Microgrid Power Quality Enhancement Using a Three-Phase Four-Wire Grid-Interfacing Compensator", IEEE TRANSACTIONS ON INDUSTRY APPLICATIONS, VOL. 41, NO.6 NOVEMBER/DECEMBER 2005
- [15] Chandana Jayampathi Gajanayake, , D. Mahinda Vilathgamuwa, Poh Chiang Loh, , Remus Teodorescu, Frede Blabjerg," Z-Source-Inverter-Based Flexible Distributed Generation System Solution for Grid Power Quality Improvement", IEEE TRANSACTIONS ON ENERGY CONVERSION, VOL. 24, NO. 3, SEPTEMBER 2009.
- [16] Jeena John, K Navatha Kumari , "Model Predictive approach for power quality improvement in distributed generation Inverter", INTERNATIONAL JOURNAL OF ADVANCED RESEARCH IN SCIENCE AND ENGINEERING, VOL.04, ISSUE 04, APRIL 2015