

Natural Refrigerant Based Solar Thermal Refrigeration System and Its Performance Optimization by MATLAB Simulation

Ratan Mandal¹& Rakesh Naskar²

¹Professor & Director, School of Energy Studies, J.U., Kolkata- 700 032, India,

²PhD, School of Energy Studies, Jadavpur University (J.U.), Kolkata-700 032,

Abstract:

Global warming is the most highlighted topic at this present situation and most concern topic is the application of refrigeration and air conditioning unit that's are tremendously increasing day by day and it has adverse impact on global warming and also increasing unpredictable power consumption. Our primary aim is to reduce global warming impact that's why we are focusing on natural refrigerants and have to reduce conventional power consumption as well as focusing power optimization in refrigeration and air conditioning unit. So, here in this paper details analysis using natural refrigerants as Isobutene (R600a) and application of solar thermal for superheating the refrigerant of R600a is presented to reduce Compressor power consumption where the analysis is carried out by MATLAB Simulation process.

Keywords:

Natural Refrigerant, Low power rated compressor, Solar Thermal, MATLAB Simulation.

Nomenclature:

AC	Air-conditioner	ODP	Ozone depletion potential
CFC	Chlorofluorocarbon	R-11	Trichlorofluoromethane
COP	Co-efficient of performance	R12	Dichlorodifluoromethane
dc/ DC	Direct current	HFC	Hydrofluorocarbon
GHG	Greenhouse Gas	KW	Kilo-watt
GWP	Global warming potential	R-600a	Isobutane
HC	Hydrocarbon		

1. Introduction:

This paper introduces an innovative measure to reduce the application of electricity for public or commercial gadgets that are installed for social modernization inside homes as well as the modernization of the system in offices. This method will undoubtedly emerge as the most economical way to lower a space's temperature while utilizing energy optimization strategies. Another significant advantage is that to run the capillary tubes, solar thermal collectors collect the sun's thermal energy and use it to perform the air conditioning system. In comparison, conventional air conditioning operating throughout the hottest day results in high power grid demand, which, during its peak usage, causes a significant drop in power outages and blackouts and increases CFC, or greenhouse gas, emissions. In both aspects, natural refrigerants are coming back into the market, and using solar thermal for refrigerant superheating also reduces power

consumption by the same rated unit, which is detailed in the MATLAB software simulation process. Various papers were also reviewed in this regard, which identified the scope of the work. Some papers' objectives relate to this topic and are explained here.

I Dauta, M. Adzria, M. Irwanto, P. Ibrahima, and M. Fitraa have investigated solar power air conditioning systems to minimise the cost of a day-to-day air conditioning system. Climate change and global warming increase air conditioning demand, with fossil fuel-generated electricity worsening global warming. In subtropical cities, air conditioning accounts for half of building electricity consumption [1]. The behaviour of the refrigerants in vapour compression refrigeration systems has been examined by Mustafa Ozsipahi, Haluk Anil Kose, Husnu Kerpicii, and Hasan Gunes through experimental investigation of R290/R600a combinations. According to

estimates from the International Institute of Refrigeration (IIR), there are 3 billion air conditioning, heat pump, and refrigeration systems operating globally, including 1.5 billion residential refrigerators. Almost 17% of all power used globally is consumed by the refrigeration industry, which includes air conditioning [2]. A modified two-phase ejector for an R600a household refrigeration cycle has been studied by Yongseok Jeon, Sunjae Kim, Dongwoo Kim, Hyun Joon Chung, and Yongchan Kim to determine the best c.o.p. and efficiency under different operating conditions. [3]. Researchers Baomin Dai, Haining Yang, Shengchun Liu, Chen Liu, Tianhao Wu, Jiayi Li, Jiayi Zhao, and Victor Nianwas studied waste heat and hybrid solar energy driving absorption sub cooling supermarket CO₂ refrigeration systems. According to the study, a hybrid solar energy and waste heat-driven absorption system. To increase supermarket energy efficiency, a sub cooled carbon dioxide (CO₂/R744) booster refrigeration system is being developed in China. The system is best suited for hot or warm climate areas with rich solar energy [4]. Alireza Riahi, Mohammad Behshad Shafii, explained in this paper that a parametric study of a vapour compression refrigeration system integrated with a PCM storage tank in Tehran city aimed to increase condenser sub-cooled temperature. The study considered various parameters and simulations in the EES software. Findings indicated that the typical unit's daily electric energy usage increased by 20.86% to 30.63% with the addition of a PCM storage tank, but also increased accessible cooling energy during cold energy discharging by 39.67% to 54.60%. Additionally, it reduced total daily CO₂ emissions by 20.7%. GWP, ODP, and environmental impacts are also important concerns for a refrigeration system and a cost-effective system for society. There are many papers where there is research on natural refrigerants, research on mixing two different natural refrigerants to increase their properties, and also different methods. So, in this project, we used a natural refrigerant, isobutene (R600a), as a refrigerant and also a solar water heating tank as a super heater. MATLAB Simulation software is used to combine both systems and make an optimal system where we are concerned with GWP, ODP, environmental impacts, and a cost-effective refrigeration system.

2. Scope of the Work:

It is clear that the design of a natural refrigerant-based refrigeration system is mainly based on software analysis, and different parameters also concern There have been different techniques of optimization for designing renewable energy-based hybrid systems [REHS] for refrigeration systems. On the basis of earlier work and the gap in knowledge, all possible solutions have been analyzed by the MATLAB simulation process.

3. Methodology

Here hybrid system basically indicates that two individual system is used to combine to make a hybrid system. They are-

- Refrigeration system with natural refrigerant
- Solar Water Heating System

At the end of this design, both systems combined and make a Hybrid refrigeration system.

- Analysis done by R600a.
- MATLAB Simulation process to find COP & Power consumption For R600a.

Properties	Evaporator Inlet	Evaporator Outlet	Solar Water Heater Outlet	Compressor Outlet	COP ₁ (Super Heating)	COP ₂ (Without Super Heating)
Temperature	-10.36	-3.256	16.75	81.86	2.55	1.97
Pressure	0.107	0.107	0.107	0.4147	7	
Enthalpy	271.9	551.7	584.1	693.5		

- Introducing Solar thermal process for refrigerant superheating state for compressor power optimization.

4. Technical Perspective

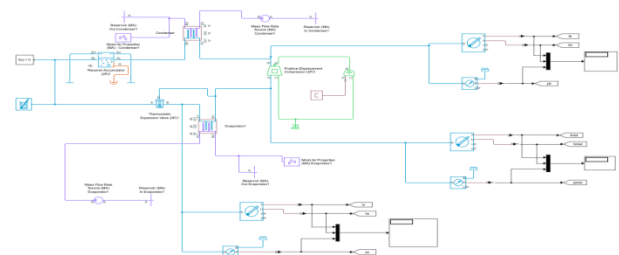

Figure 1: Refrigeration system with natural refrigerant

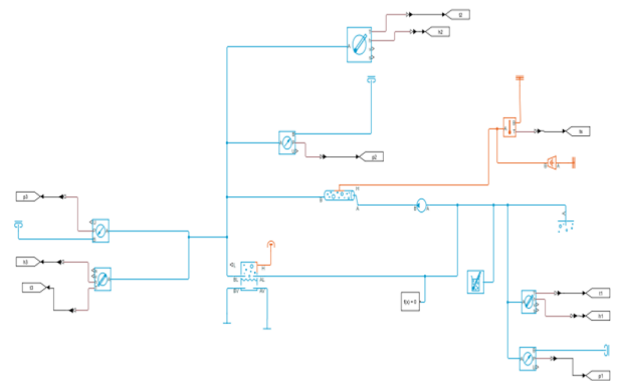

Figure 2: Solar Water Heating System

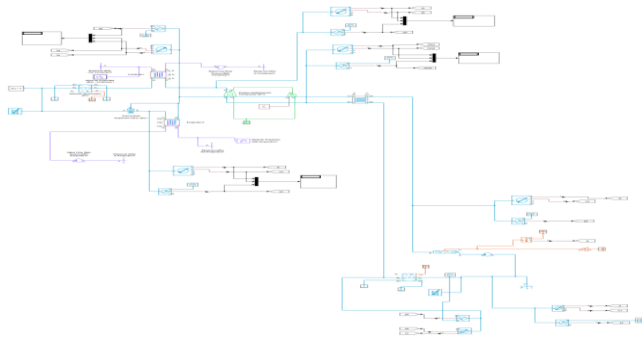

Figure 2.1: Combined System (Hybrid System)

Table No.1 Data of Normal Refrigeration System

Data of Normal Refrigeration System (Standard)

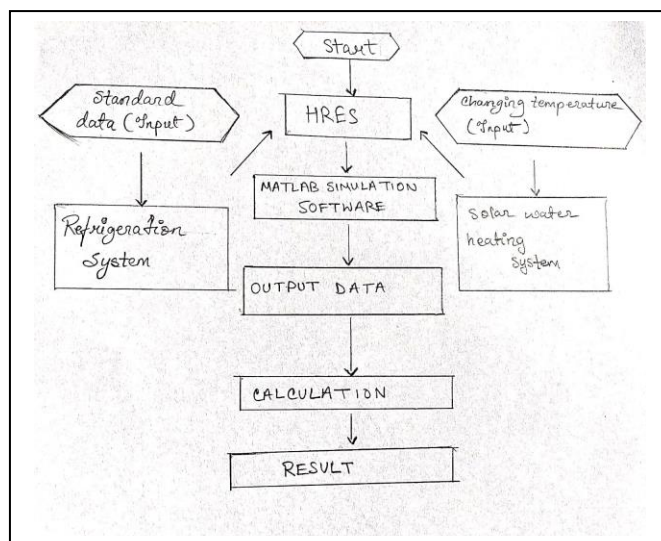

Figure 2.2: Data analysis algorithm of the hybrid system as MATLAB Simulation Input & output relation

Hybrid system is basically a combination of Refrigeration System and Solar Water Heating System.

Properties	Evaporator inlet	Evaporator outlet	Compressor Outlet	C.O.P
Temperature	-10	-2	73	2.35
Pressure	.108	.1084	.404	
Enthalpy	266.3	553.5	675.7	

Table No. 2: Optimum Hybrid System

Data of Optimum Hybrid System

In Refrigeration System Fig. 1, there are several components that play a vital role in the refrigeration system. The main components

are: 1. evaporator; 2. compressor; 3. condenser; and 4. expansion device. We used to calculate three points in a refrigeration system: 1. the entry point of refrigerant in the evaporator; 2. the exit point of the evaporator; and 3. the compressor exit point. This model is completely designed in MATLAB simulation software. We consider different parameters through this process to find an optimum design. All values are calculated based on the three points mentioned above. In this process, we used the natural refrigerant isobutene as a refrigerant.

NO	PROPERTIES	EVAPORATION INLET	EVAPORATOR OUTLET	SOLAR WATER HEATER OUTLET	COMPRESSOR OUTLET	C.O.P 1 (With superheating)	C.O.P 2 (without superheating)
1.	TEMPERATURE	-15.08	-7.01	16.25	86.48	2.321	1.766
	PRESSURE	0.0888	0.0888	0.0888	.4096		
	ENTHALPY	271	546.8	584.1	702.9		
2.	TEMPERATURE	-14.14	-6.293	16.35	85.1	2.38	1.815
	PRESSURE	0.09229	0.09229	0.09229	.4069		
	ENTHALPY	271.3	547.8	584.1	700.1		
3	TEMPERATURE	-13.05	-5.45	16.48	86.5	2.336	1.8018
	PRESSURE	0.09632	0.09632	0.09635	.4251		
	ENTHALPY	271.5	548.8	584	702.7		
4.	TEMPERATURE	-11.78	-4.395	16.6	82.3	2.523	1.93
	PRESSURE	0.1013	0.1013	0.1013	0.4072		
	ENTHALPY	271.7	550.3	584.1	694.5		
5.	TEMPERATURE	-10.36	-3.256	16.75	81.86	2.557	1.97
	PRESSURE	0.107	0.107	0.107	0.4147		
	ENTHALPY	271.9	551.7	584.1	693.5		
6.	TEMPERATURE	-8.501	-1.728	16.94	79.56	2.689	2.08
	PRESSURE	0.115	0.115	0.115	0.4189		
	ENTHALPY	272.2	553.8	584.2	688.9		
7.	TEMPERATURE	-6.81	-0.3081	17.17	75.96	2.90	2.243
	PRESSURE	0.1225	0.1225	0.1225	.4092		
	ENTHALPY	272.2	555.6	584.2	681.9		
8.	TEMPERATURE	-4.824	1.346	17.42	73.12	3.10	2.413
	PRESSURE	0.132	0.132	0.132	0.4125		
	ENTHALPY	272.4	557.9	584.3	676.2		
9.	TEMPERATURE	-2.882	3.034	17.73	73.91	3.107	2.464
	PRESSURE	0.1417	0.1417	0.1417	0.4394		
	ENTHALPY	272.4	560.2	584.4	677		
10.	TEMPERATURE	-0.8061	4.77	18.02	67.33	3.60	2.83
	PRESSURE	0.1526	0.1526	0.1526	0.4147		
	ENTHALPY	272.5	562.4	584.4	664.8		
11.	TEMPERATURE	1.128	6.514	18.37	63.94	3.96	3.13
	PRESSURE	0.1636	0.1636	0.1636	0.4109		
	ENTHALPY	272.5	564.9	584.6	658.3		
12.	TEMPERATURE	3.191	8.252	18.71	64.51	3.97	3.218
	PRESSURE	0.1755	0.1755	0.1755	0.4391		
	ENTHALPY	272.6	567.1	584.6	658.6		
13.	TEMPERATURE	5.271	10.16	19.09	57.59	4.83	3.887
	PRESSURE	0.1887	0.1887	0.1887	0.4114		
	ENTHALPY	272.7	569.7	584.7	646.1		

Table 3: Data sheet of the hybrid system as MATLAB Simulation Input & output relation

In the solar water heating tank system, fig. 2 is used to superheat the refrigerant. In this system, the sun's rays incident on the solar heating panel, which is approx. 600 watts. After that, this heat energy is stored in the form of

water and transferred to the tank with the help of a motor. There is basically a sun's ray, a solar panel, a water tank, and a motor.

In the hybrid system in Fig. 2.1, a heat exchanger is used to transfer the heat to the refrigerant.

Using well-known equations, thermodynamic characteristics at each state and performance metrics were calculated.

1. The pressure ratio = Compressor Output pressure / Compressor Input pressure
2. The Isentropic Compression work, W_{comp} (kJ/Kg) = Compressor outlet enthalpy – Compressor inlet enthalpy
3. The refrigerating effect (RE) (kJ/Kg) = Evaporation outlet enthalpy - Evaporation inlet enthalpy
4. The power per ton of refrigeration (P/TR) (kW) = $3.5 W_{comp} / RE$ (4)
5. The coefficient of performance (COP) = RE / W_{comp}

In this system we discuss about evaporation load, solar heating load and compressor work. According to the data sheet (Table 3) we understand that no.5 is the optimum design of the hybrid system.

So, according to the no.5 row we calculate evaporation effect or load of the hybrid system.

$$\begin{aligned} \text{Evaporation effect} &= (\text{Evaporation outlet enthalpy} - \text{Evaporation inlet enthalpy}) \text{ kJ/kg} \\ &= 551.7 - 271.9 \text{ kJ/kg} \\ &= 279.8 \text{ kJ/kg} \end{aligned}$$

And now we calculate General Refrigeration evaporation effect or load.

$$\begin{aligned} \text{Evaporation effect} &= (\text{Evaporation outlet enthalpy} - \text{Evaporation inlet enthalpy}) \text{ kJ/kg} \\ &= 553.5 - 266.3 \text{ kJ/kg} \\ &= 287.2 \text{ kJ/kg} \end{aligned}$$

If we compare the above refrigeration effect of the normal system and the hybrid system, then we see that normal system evaporation effect is better.

Now we calculate Compression work of the hybrid system.

$$\begin{aligned} \text{Compression work} &= (\text{Compressor outlet enthalpy} - \text{Compressor inlet enthalpy}) \text{ kJ/kg} \\ &= 693.5 - 584.1 \text{ kJ/kg} \\ &= 109.4 \text{ kJ/kg} \end{aligned}$$

Now we calculate of the normal refrigeration system compression work.

$$\begin{aligned} \text{Compression work} &= (\text{Compressor outlet enthalpy} - \text{Compressor inlet enthalpy}) \text{ kJ/kg} \\ &= 675.7 - 553.5 \text{ kJ/kg} \\ &= 122.2 \text{ kJ/kg} \end{aligned}$$

Now we can see that compression work of hybrid system is less than the general refrigeration system.

This is happened only because of the help of Solar heating system which reduce the compression work. **Sonow we calculate how much solar heating is done on the hybrid system.**

$$\begin{aligned} \text{Solar heating system load} &= (\text{Compressor inlet enthalpy} - \text{Evaporation outlet enthalpy}) \text{ kJ/kg} \\ &= 584.1 - 551.7 \text{ kJ/kg} \\ &= 32.4 \text{ kJ/kg} \end{aligned}$$

So solar heating system reduce the compression work by 32.4 kJ/kg, which will help the hybrid system to increase the c.o.p of the system.

C.O.P -

C.O.P is the refrigeration effect divided by the compressor work performed is known as the coefficient of performance, or C.O.P. Higher COPs are associated with reduced energy (power) consumption, higher efficiency, and lower operating costs.

$$\text{C.O.P} = \text{Refrigeration effect} / \text{Compressor work done}$$

Calculation of the C.O.P of the normal refrigeration system.

$$\begin{aligned} \text{C.O.P} &= \text{Refrigeration effect} / \text{compression work done or load} \\ &= 287.2 \text{ kJ/kg} / 122.2 \text{ kJ/kg} \\ &= 2.35 \end{aligned}$$

Calculation of C.O.P of the Hybrid system.

$$\begin{aligned} \text{C.O.P} &= \text{Refrigeration effect} / \text{compression work done or load} \\ &= 279.8 \text{ kJ/kg} / 109.4 \text{ kJ/kg} \\ &= 2.557 \end{aligned}$$

The C.O.P. of the system is defined by the coefficient of the performance of the system. If COP is high, then it is directly proportional to the use cost; if COP is increasing, then use money is decreasing; and if COP is decreasing, then consumer money will be increasing.

According to the COP, we understand that solar heating systems are beneficial for consumers.

In refrigeration systems, compressor work is an important criterion to compare the input power of a hybrid system with that of a normal refrigeration system. So we calculate the power input per tonne of refrigeration between the hybrid system and the normal refrigeration system.

TR -

This term is used in refrigeration systems. TR's full form is Ton of Refrigeration. A tonnage of refrigeration, also called a refrigeration tonnage or TON, is a unit of power where we calculate how much heat is extracted from 1000 kg of water

at 0 degrees Celsius to convert into 0 degrees Celsius in 24 hours.

Latent heat of ice = 335 KJ/Kg

$$\begin{aligned}
 1 \text{ TR} &= 1000 \times 335 \text{ KJ in } 24 \\
 &\text{hours} \\
 &= (1000 \times 335) / (24 \times 60) \\
 &= 232.6 \text{ KJ/min} \\
 &= 3.5 \text{ KJ / sec}
 \end{aligned}$$

Calculation of power input in the Normal Refrigeration System is -

$$\begin{aligned}
 \text{The power per ton of refrigeration (P/TR) (kW)} &= 3.5 \\
 \text{Wcomp/ RE} & \\
 &= 3.5 * 122.2 \\
 /287.2 & \\
 &= 1.489 \text{ kW} \\
 &= 1489 \text{ watt}
 \end{aligned}$$

Calculation of power input in the Hybrid Refrigeration System is -

$$\begin{aligned}
 \text{The power per ton of refrigeration (P/TR) (kW)} &= 3.5 \text{ W} \\
 \text{comp / RE} & \\
 &= 3.5 * 109.4 / 279.8 \\
 &= 1.368 \text{ kW} \\
 &= 1368 \text{ watt}
 \end{aligned}$$

$$\begin{aligned}
 \text{Compressor work saves per TR is (kW)} &= (1.489 - 1.368) \text{ Kw} \\
 &= .121 \text{ kW per TR.} \\
 &= 121 \text{ watts}
 \end{aligned}$$

24 hours Hybrid system saves power input = 121 watt
Then, 365 days Hybrid system saves power input = 121 * 365 = 44,165 watts.

COMPARISON BETWEEN HYBRID SYSTEM AND NORMAL SYSTEM

Refrigerant	Pressure ratio	Refrigeration effect (kJ/kg)	Compressor work (kJ/kg)	C.O. P	Power per TR (kW/TR)
Hybrid system	3.875	279.8	109.4	2.557	1.368
Normal System	3.74	287.2	122.2	2.35	1.489

COMPARISON OF CHARACTERISTICS OF HYBRID SYSTEM AND NORMAL REFRIGERATION SYSTEM BY MATLAB SIMULATION

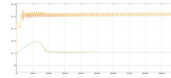

Figure 3: Variation in pressure at evaporator and condenser site in Hybrid system

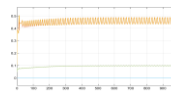

Figure 4: Variation in pressure at evaporator and condenser site in Normal system

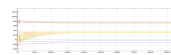

Figure 5: Variation in Temperature in Hybrid system

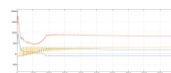

Figure 6: Variation in Temperature in Normal system

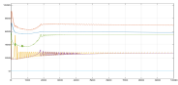

Fig.7: Variation in Enthalpy in Hybrid system

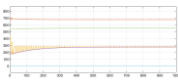

Fig. 8: Variation in Enthalpy in Normal system

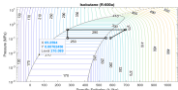

Fig. 9: P-H diagram of the Hybrid system under superheating condition

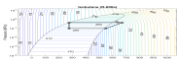

Fig. 10: P-H diagram of the Normal system without superheating condition

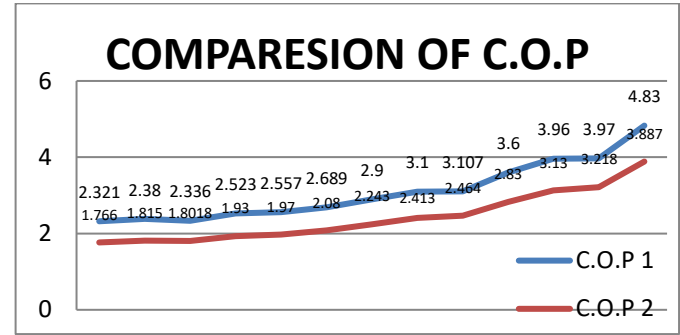

FIG.11: comparison between COP1 and COP 2.

5. Result and Discussion

Pressure graph

In the pressure graph, we see two different pressures, and they are between 1 bar and 4.2 bar. After some time, the pressure will be at a constant level. At the very first time when the compressor works, the mass flow rate is not constant, and so pressure suddenly rises, but after that, when the mass flow rate of refrigerant is going at a constant rate, it will be at a constant value. They are basically at evaporative pressure and condenser pressure, which is after compression.

Temperature graph

In temperature graph we get four type temperature lines, they are at different position of refrigeration system. There is one line which is coming from evaporator temperature at -3-degree centigrade it will jump suddenly. There are two reasons, first one is when compression starts mass flow rate is less that time fewer refrigerant compresses high due to this pressure is increased and temperature is increased because pressure is directly proportional to temperature. Second reason is the heating effect of solar water heater which heated the refrigerant coming from the evaporator outlet that's why temperature increased initially. But after some time when compressor is running, we will see only the heating effect of solar water heating tank.

C.O.P compression

C.O.P. comparison is one of the main criteria for finding the optimum design among all designs. We all know that C.O.P. is directly proportional to consumer costs. So here we plot COP1 and COP2 in a single graph of all the simulations, which were done in MATLAB simulation software, to compare and find out the optimum design. In C.O.P. 1, it is

calculated when superheating is done, but in C.O.P. 2, there is no superheating.

6. Conclusion:

This paper introduces an optimal design and assessment of a standalone hybrid system for household use. Initially, we studied carefully the working process of the refrigeration system and the working conditions where it provides the maximum C.O.P. at the corresponding temperature and pressure. Then we read the solar heating tank properly and try to understand the working procedure. Here, we took natural refrigerant as a refrigerant. After that, MATLAB simulation software is used to form a hybrid system of a natural refrigerant-based refrigeration system and a solar water heating system. In this simulation software, we simulate a lot of simulations and get a lot of data. From this data, we get our optimal design, where we get maximum C.O.P. at the corresponding temperature and pressure.

The major result of the present work is summarised as follows:

1. The optimal size of the hybrid system is a combination of a solar water heating tank with 2 bar pressure at a constant 50-degree temperature and a refrigeration system with a C.O.P. of 2.57.
2. The optimal design gives a better C.O.P. than a traditional design. It saves a lot of money for the consumer.
3. It requires a high initial investment because here we installed a combined system.
4. It provides multipurpose uses.
5. A solar heating tank is used to increase the C.O.P. of the refrigeration system and is also used for home use.
6. This type of system is really useful for hospitals, hotels, industries, etc.

This system is practically possible for the society, so we design a prototype in MATLAB in such a way that it provides theoretical as well as practical possibilities. Its investment is high initially but there will be little expenses further. Here solar water heating system is also used for multipurpose application. There is used natural refrigerant, so no pollution and global warming is happened.

- The future of refrigeration is expected to be more energy efficient and sustainable.
- This is due to a growing awareness of the environmental impact of these technologies, as well as advances in materials and technologies that allow for more efficient cooling systems.
- Additionally, there is a growing trend towards using natural refrigerants, such as isobutane (R600a) which are less harmful to the environment than traditional refrigerants.

- Overall, the future of refrigeration and air conditioning will be driven by a combination of energy efficiency, sustainable refrigerants, advanced system designs, smart technology integration, thermal energy storage, waste heat recovery, and adherence to green building standards.

Acknowledgement: The team of researchers is indebted to School of Energy Studies, J.U., Kolkata, for providing infrastructural support for this work from time to time.

References:

- [1] I. Dauta, M. Adzriea, M. Irwantoa, P. Ibrahim, M. Fitraa, [2013]. Solar Powered Air Conditioning System. *Energy Procedia* 36,444 – 453. doi: 10.1016/j.egypro.2013.07.050.
- [2] Mustafa Ozsipahi, Haluk Anil Kose, HusnuKerpicci, Hasan Gunes, [2022]. Experimental study of R290/R600a mixtures in vapor compression refrigeration system. *International Journal of Refrigeration* 133, 247–258. <https://doi.org/10.1016/j.ijrefrig.2021.10.004>.
- [3] Yongseok Jeon, Sunjae Kim, Dongwoo Kim, Hyun Joon Chung, Yongchan Kim, [2017]. Performance characteristics of an R600a household refrigeration cycle with a modified two-phase ejector for various ejector geometries and operating conditions. *Applied Energy* 205,1059–1067. <http://dx.doi.org/10.1016/j.apenergy.2017.08.148>.
- [4] BaominDai ,Haining Yang , Shengchun Liu , Chen Liu , Tianhao Wu , Jiayi Li , Jiayi Zhao , Victor Nian,[2022].Hybrid solar energy and waste heat driving absorption subcooling supermarket CO2 refrigeration system: Energetic, carbon emission and economic evaluation in China. *Solar Energy* 247,123–145. <https://doi.org/10.1016/j.solener.2022.10.009>.
- [5] Alireza Riahi, Mohammad BehshadShafii, [2023]. Parametric study of a vapor compression refrigeration system integrated with a PCM storage tank for increasing condenser sub-cooled temperature. *Case Studies in Thermal Engineering* 47,103100. <https://doi.org/10.1016/j.csite.2023.103100>