

P&O Optimization in Solar Energized High Voltage DC Power Transmission Through VSC Technology

Karunakar T^{1*}, F T Josh², J. Jency Joseph³, P. S. Mayurappriyan⁴, Dr. M. S. P. Subathra⁵

^{1*}Research Scholar, Karunya Institute of Technology and Sciences, Coimbatore, India.

Email: karunthk2@gmail.com

²Assistant Professor, Karunya Institute of Technology and Sciences, Coimbatore, India.

Email: josh@karunya.edu

³Assistant Professor, Karunya Institute of Technology and Sciences, Coimbatore, India.

Email: jencyjoe@karunya.edu

⁴Professor / EIE, Kumaraguru College of Technology, Coimbatore, India.

Email: mayurappriyan.ps.eie@kct.ac.in

⁵Professor / RA, KITS, Coimbatore, India

Email: subathra@karunya.edu

***Corresponding Author:** Karunakar T

^{*}Research Scholar, Karunya Institute of Technology and Sciences, Coimbatore, India.

Email: thadkapallykarunakar@karunya.edu.in

Abstract

High voltage DC transmission allows higher power and stabilized higher DC voltages to longer distances with lower transmission losses and higher system stabilities, the power generation through wind energy or solar energy. The HVDC system allows the system to transmit the power which is generated by solar to longer distances. The solar energy to be converted into DC power and can be induced and integrated with the existing grid on a large scale. This paper aims at integrating the AC grid and VSC HVDC transmission system, the power regenerated mainly through solar energy, and the penetration of renewable energy is examined with regard to bipolar links for HVDC. The complete transmission and generation part is simulated using MATLAB/SIMULINK. Simulated results clarify that the HVDC system is more adoptable in case of short circuit levels and power losses in the long transmission systems. Further simulation studies are observed by keeping the existing station equipment parameters of the VSC HVDC converter stations between the Pugalur located in Tamil Nadu, India (High solar energy region) and Thrissur located in Kerala, India (Low solar energy region). The observation of studies enumerates the necessity of HVDC technology implies to solar energy penetration into the utility grid.

Keywords: Solar energy, HVDC, power losses, P&O algorithm, Dynamic simulation.

1. INTRODUCTION

The electricity demand is increasing in India as well as globally. As a result of this more no. of thermal plants or plants based on fossil fuel is running to supply the demand, which leads to the heavy burning of coal making the greenhouse effect and causing Global warming. To avoid conventional fossil power, the global system should move towards renewable power generating sources. Less coal or fossil burning makes a healthier environment for future generations. As per the explanation by Chattopadhyay, renewable energy will play a major role in the Indian energy market and Global energy markets. Increasing the efficiency of the

thermal plant will reduce coal burning for the same power generation and other energy-generating sources, like renewable energy, should be a replacement for coal [1-9]. Electrical theft become a significant energy loss in developing nations [10-13]. The transmission and distribution losses in India is around 23% of total power generation. As per TERI [14], losses could be up to 50% in a study. The power losses as a result, generating the extra electricity will wind up with power loss for the generating plant. According to Carolien et al in India, by reducing the T&D losses, CO₂ emissions can be cut by 6% and power plant production efficiency can be increased by 9%.

As per T&D loss consideration, an adoptable transmission system is required for the long transmission line. For long distances, HVDC system is preferable over HVAC, as transmission losses can be minimized and system control stability will increase. Hempelt analysis of the long-distance transmission systems present state of art using Ultra HVDC [15-17]. HVDC gives a better option in interconnecting the asynchro grids and is particularly suitable for renewable power generating systems [18]. For renewable power generation, the HVDC converter's significance is mentioned in several researches [19-23].

Renewable power generation integrated with HVDC gives better optimal power transmission and distribution losses. In this paper discussed solar power integration with VSC HVDC for power transmission for longer distances. The using PV module's strings and substrings are connected to the existing grid by a dedicated inverter or an inverter with DC/DC converter connected to solar panels [24-25]. Battery charger scheme for the solar system to reduce output ripples mentioned in [26]. The wide range of solar power conversion and conventional dc-dc converters for PV cells are examined [27]. Battery storage is not required for PV integrated with a grid with optimized controls [28-29].

This paper presents the integration of the PV-cell concept in the existing VSC HVDC transmission system in India. This paper presents a new method of connecting panel voltages to local AC grid voltages and transmitting the power to longer distances using the VSC HVDC transmission system. This concept is applied to the existing HVDC link between Pugalur AC Grid and Thrissur AC Grid specifications for study purposes. The MATLAB simulation studies are conducted with integration of solar photovoltaics' at Pugalur AC Grid (High sun light region), is transmitting the power to Thrissur AC Grid (Low sunlight region) through the VSC HVDC link. Several studies are made on solar power generation with the P&O

algorithm, grid voltage disturbances and HVDC link volatages.

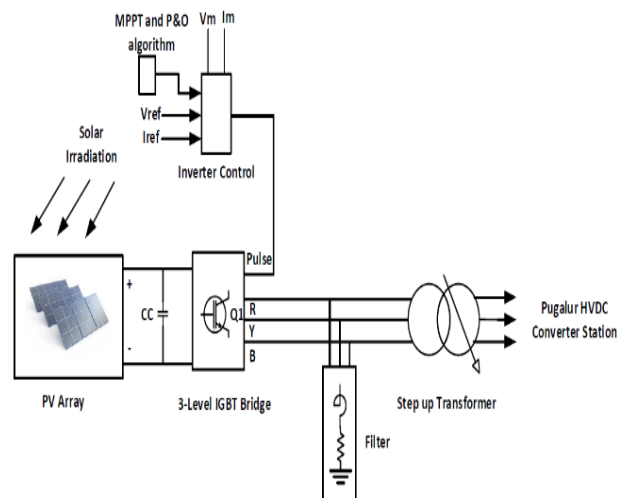

Fig. 1. Solar photovoltaic penetration illustration into the grid system.

The solar power generation equation is given below,

$$E = A \times r \times H \times PR$$

E is the energy generated in KWH, A is the total area of the panel (m²), r is solar panel yield (%), H is the annual average solar radiation on tilted panels and PR = Performance ratio, which signifies the performance of the PV cell irrespective of the installation method and other losses considered in practical installation. The solar power is directly fed to a 3-level IGBT inverter model, which converts PV-cell DC power to AC power. Gating pulses for the IGBT inverter are generated by the inverter control unit. The inverter control unit works on maximum power point tracking (MPPT) with perturb and observe algorithm. MPPT with the P&O algorithm takes the continuous feedback of measured PV-cell voltage and currents, DC Voltage, inverter voltage output and current output. Fig. 1 gives the prototype model of PV-cell system integration with an AC grid and transmitting the power through the VSC HVDC system, the model is simulated in MATLAB Simulink.

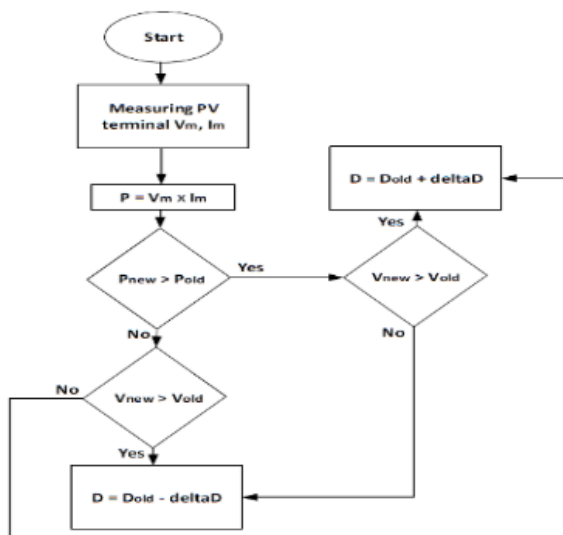

Fig. 2. P&O algorithms used in Solar PV MPPT model.

Typically, the P&O algorithm is used in MPPT model to track the maximum power of the solar cell. The PV output power is periodically measured and compared with the previous power to track out the maximum permissible power generation from the solar grid. It continuously monitors the PV voltage to get MPP, V_{new} , P_{new} are continuously monitored over V_{old} , P_{old} . If $P_{new} > P_{old}$ & $V_{new} > V_{old}$, then the inverter control system will generate gate pulses to the inverter by the PWM technique. The Pulse width is based on the maximum power tracking model and controls the inverter output values. The MPP of the solar system is tracked by measuring the voltage and currents by comparing the old values to get the energy tracked out. The solar energy is directly fed to the AC grid by controlling the inverter using MPP mode.

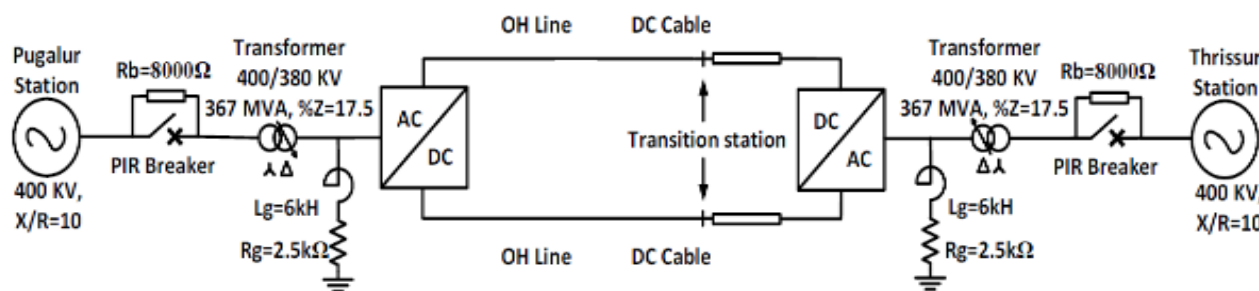

Fig. 3. Typical VSC HVDC transmission line between Pugalur and Trichur

I. HVDC LINK AND CONVERTER STATIONS

This paper mainly discussed solar power flow from the rectifier station to the inverter station and the simulation of the VSC-HVDC transmission system. In MATLAB, solar power with MPPT and P&O algorithm gives prominent power to the AC grid. The IGBT equivalent model is used to convert AC power to DC power and vice versa. The operating DC voltage levels are +/- 320 KV. The two converter stations are connected through over line for 250 km and an underground cable for 32 km. The link is having a capacity of 2000MW power flow in both directions.

VSC HVDC is becoming is prominent power transmission over a longer distance with better stability, mainly power generation through renewable energy sources. VSC HVDC converters mainly deal with IGBT modules depending on the power level the module capacity will be decided. The Modular multilevel converters (MMCs) make the two to three-level topologies and make a major development in this technology. The technology makes use of MMC and submodule.

Sub module is an IGBT half-bridge connected to a capacitor, which allows the capacitor to charge and discharge in a faster and more reliable manner. The more no. of MMC sub-module for a higher level of operating voltages. In MATLAB implementation used an equivalent model of the IGBT Bridge to get better simulation results.

The complete model is implemented in MATLAB simulation and the existing transmission system and real-time equipment parameters are considered for the model as mentioned in Table 1.

There is a Voltage Source Converter (VSC) fed HVDC project under construction connecting Pugalur to North Trichur (Kerala) with the same configuration and rating. This work details the methodologies suitable to enhance the operational performance of the system. The simulations are planned to conduct based on this real-time data.

Table 1. HVDC Parameters.
HVDC Characteristics

Rated Power Flow	2000 MW
MMC Levels	331
Sub-module	Half-bridge
Rated Pole DC Voltage (Ud)	640 kV (Pole to Pole)
Pugalur AC Grid	50 Hz, 400 kV, 36.4 GVA, X/R =10
Thrissur AC Grid	50 Hz, 400 kV, 36.4 GVA, X/R =10
Converter Transformer	400/380 kV, 367 MVA Leakage Impedance = 17.5%
Neutral Grounding Reactor	Lg = 6 kH, Rg = 2.5 kΩ
Power Transmission Characteristics	
Conductor size	2500 mm ²
Conductor	Copper
Insulation	XLPE insulation
OHL length	143 km
Cable Length	32 km
OHL DC Resistance	23.27 mΩ/km
Cable DC Resistance	9.2 mΩ/km

MMC Sub-modules Characteristics		
Type	Half bridge	
Nominal Frequency	Switching	100 Hz
Capacitor	8.5 ±2% mF	
Peak Turn-off Current	3300 A	
DC Reactor per arm	90 H	

II. HVDC System with PV Penetration

VSC HVDC system is become more viable in the 2000s, as it connects renewable energy generation to the existing grid. Power transmission range varies from 1MW to thousands of megawatts based on the abundance of renewable power at a particular location. There are many nationwide and interregional transmission projects being developed in India and China utilizing HVDC/UHVDC and FACTS devices. Solar power generation is feasible, where the abundance of solar energy from the Sun. Catching the sunlight and converting it to solar power requires a photo voltaic system (PV-Cell). The basic PV cell connection with the converter and AC grid as shown in Fig. 4.

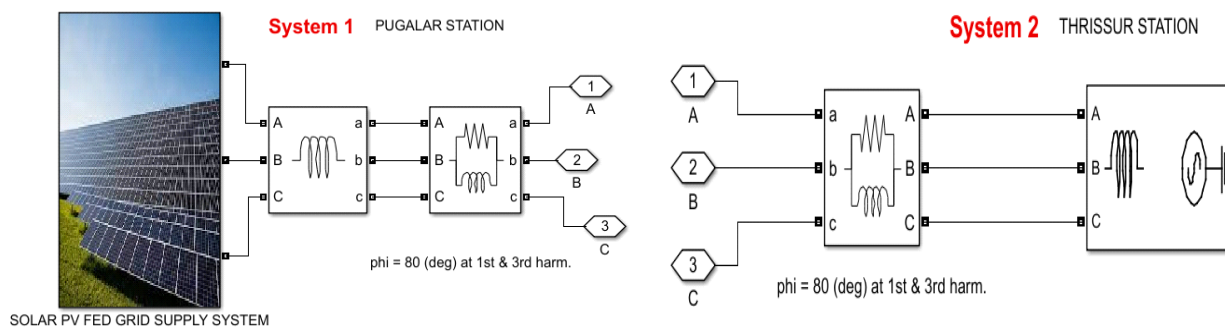

Fig. 4. Solar power penetration into the AC grid and VSC HVDC Transmission system.

VSC HVDC system is become more viable in the 2000s, as it connects renewable energy generation to the existing grid. Power transmission range varies from 1MW to thousands of megawatts based on the abundance of renewable power at a particular location. There are many nationwide and interregional transmission projects being developed in India and China utilizing HVDC/UHVDC and FACTS devices. Solar power generation is feasible, where the abundance of solar energy from the Sun. Catching the sunlight and converting it to solar power requires a photo voltaic system (PV-Cell).

The basic PV cell connection with the converter and AC grid is shown in Fig. 4.

The Pugalur station is located at the southern state of India, which is exposed to high sunlight during the daytime throughout the year. Solar power can be utilized economically and transmit the power to other areas. Already a VSC HVDC transmission system is commissioned in the southern part of India, which connects the Pugalur in Tamil Nadu to Thrissur in Kerala. A simulation model is created with a VSC HVDC transmission system, one station is having solar power as a

generating source and it is transmitted to another station.

III. Simulation Results

The Dynamic system simulation is executed in MATLAB Simulink as shown in Fig. 5. The work mainly focuses on real-time system analysis for integrating the existing system with the new system. This paper focuses on real-time data modelling for the new renewable source penetration between the two existing stations Pugalur and Thrissur in India, grid specifications are mentioned in Table 1. Fig. 3 gives an understanding model of Pugalur and Thrissur converter stations. Fig. 4 briefs the solar-fed AC grid at Pugalur as rectifier station 1 and Trichur as inverter station 2 and their control scheme and energy conversion system.

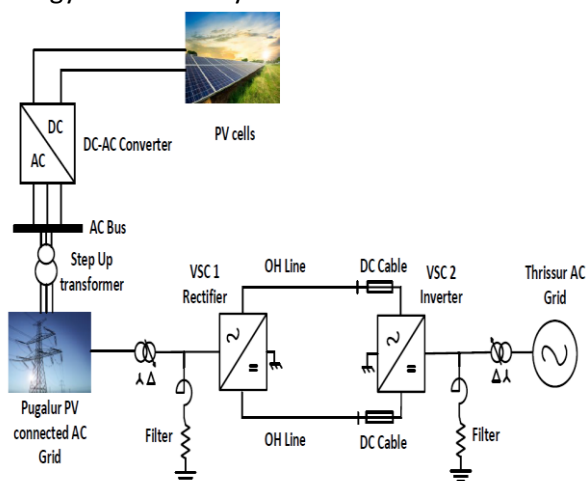

Fig. 5. Solar PV-fed Pugalur and conventional-fed Trichur station modelling

IV. Results Summary

1. Fig. 8 represents the voltage and current waveforms at solar PV fed to the AC grid at Pugalur station 1. The data is real-time as a result of MATLAB programming considering the area irradiation value and temperature. The Power availability of the area graph can be observed as shown in Fig. 9.
2. The Solar power at the grid is the input to the Pugalur HVDC converter station 1. The converter DC voltage and DC power are scaled to per unit value for easy understanding. The voltage input, voltage per unit and the per unit

power input of DC equivalent is illustrated in fig. 10.

3. The existing AC grid at Trichur side HVDC converter station 2, the DC power is received from Pugalur Solar PV plant. The converter terminal DC voltage and power graphs get from fig. 11, the values are scaled per unit value and the DC equivalent per unit power is illustrated.
4. The Pugalur side HVDC converter station 1 real-time value i.e., the input-controlled voltage, active power, and apparent power, per unit values of three phase-controlled voltages and three phase-controlled currents respectively are shown in Fig. 12.
5. The Trichur HVDC converter station 2 responses are illustrated in fig. 13 i.e., input-controlled voltage, active power, apparent power, per unit values of three phase-controlled voltages and three phase-controlled currents respectively are shown in fig. 13.
6. The Pugalur converter station (station-1: Pugalur station) filter performance is illustrated in fig. 14 and quadrature axis current, direct axis current, modulation index and voltage reference are generated for the HVDC converter gate pulse are shown in fig. 14 respectively.
7. Trichur HVDC converter station (station-2: Thrissur station) filter performance is represented in fig. 15. And the direct axis current, modulation index, quadrature axis current and the voltage reference for the HVDC converter pulse are shown in Fig. 15 respectively.
8. The HVDC Pugalur converter station (station-1: pugalur station) connected grid parameters are illustrated in fig. 16. The control dc link voltage, compensation, improved station-1 profile and station 1 terminal three-phase voltages are shown in fig. 16 respectively.
9. The Trichur (station-2: Thrissur station) AC grid parameters are illustrated in fig. 16 i.e., improved station-2 profile, the control dc link voltage, compensation voltage and station 2 voltage three-phase voltages are shown in fig. 17 respectively.

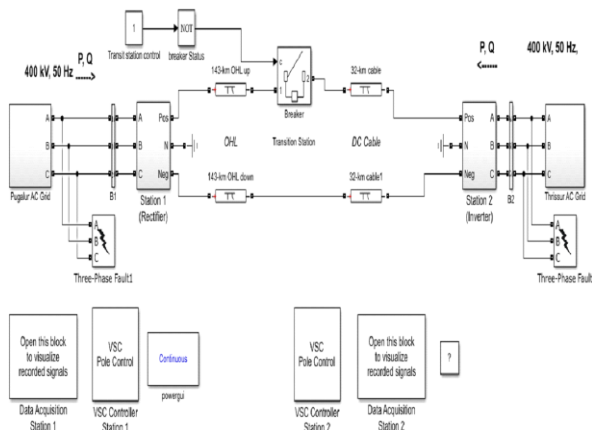

Fig. 6. Dynamic simulation model of HVDC System

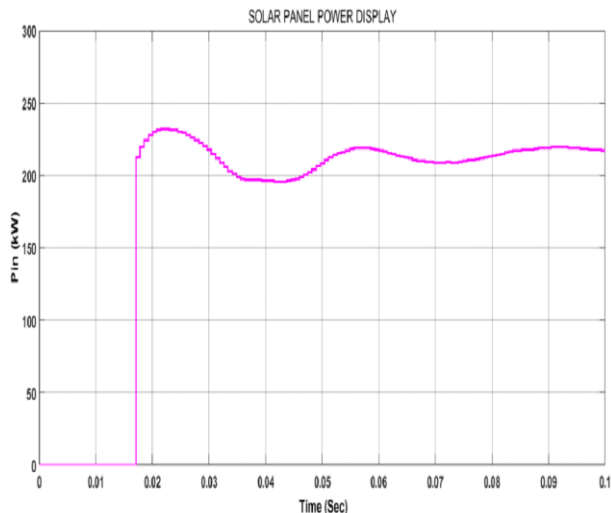

Fig. 9. Solar PV power inflow from PV array illustration.

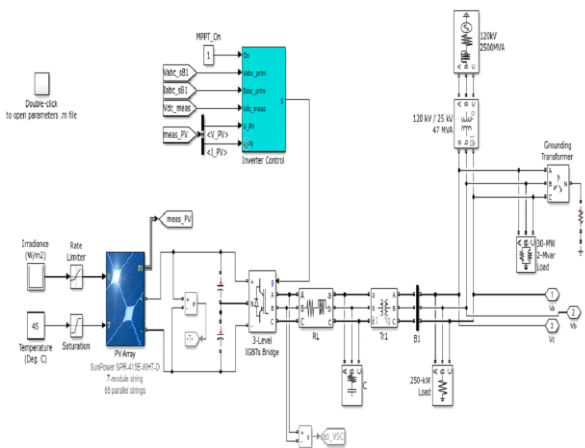

Fig. 7. Solar PV fed grid Pugalur supply station illustration.

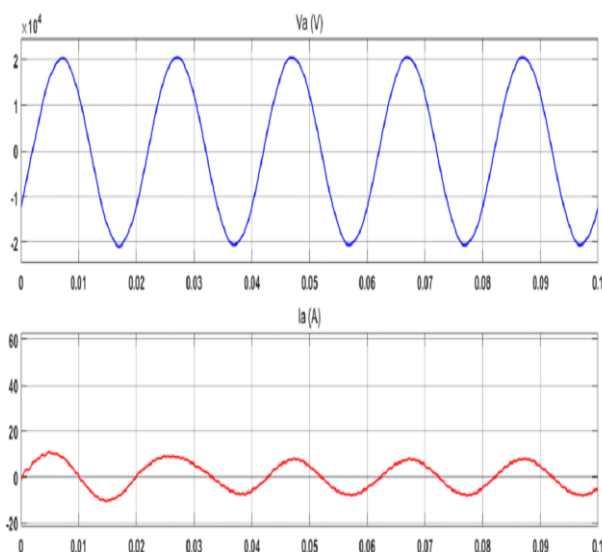

Fig. 8. Solar PV fed grid Pugalur supply station voltage and current illustration

V. Conclusion

Currently, the transmission system can integrate with renewable energy sources seamlessly into the broad portfolio of HVDC availability. By combining different HVDC technologies LCC & VSC, back-to-back connected grids and long-distance transmission networks can provide improved access to renewable energy resources over conventional ones like wind, solar, hydro and ocean tides. Etc. Ac power distribution can be strengthened with DC Power transmission for longer distances. HVDC is a proven technology in power transmission around the globe and proven technology to get sustainable and environmentally friendly power. Further analysis of power systems is discussed in comparison with conventional systems. This paper extracts the grid dynamic analysis and enables further research in renewable power generation and transmission over longer distances. The simulation studies enable the future scope of grid integration with renewable power generation.

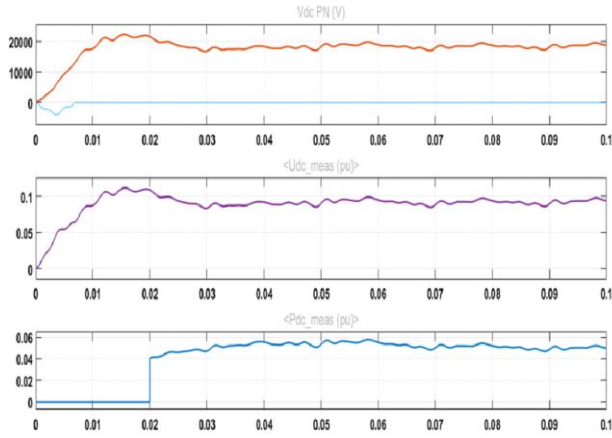

Fig. 10. Station-1 output illustration

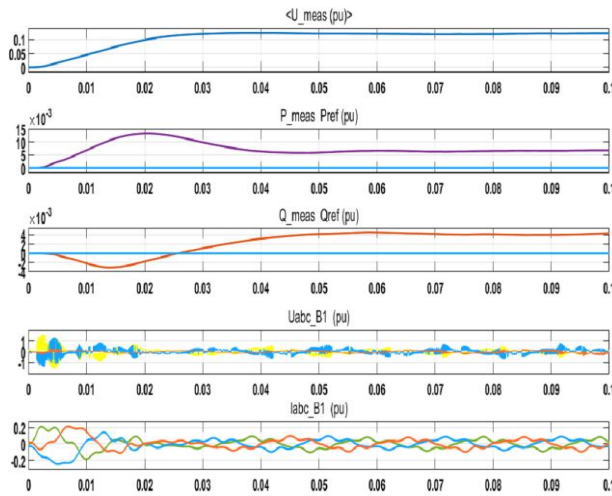

Fig. 11. Station-2 output illustration.

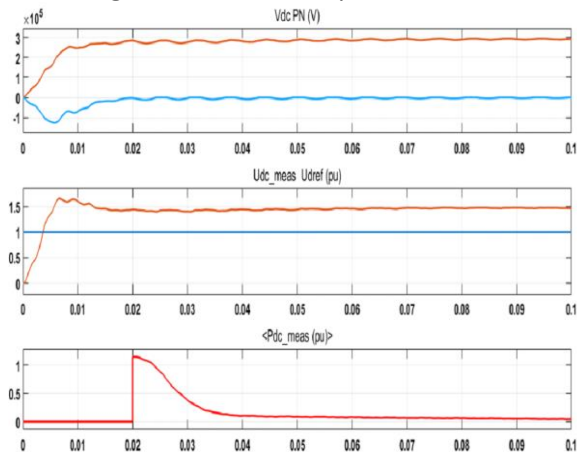

Fig. 12. Station-1 VSC control station performance illustration.

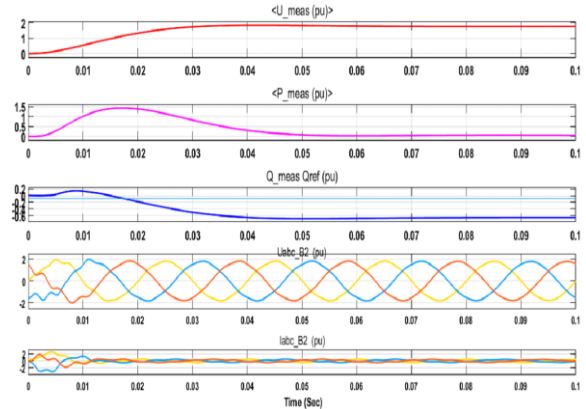

Fig. 13. Station-2 VSC control station performance illustration.

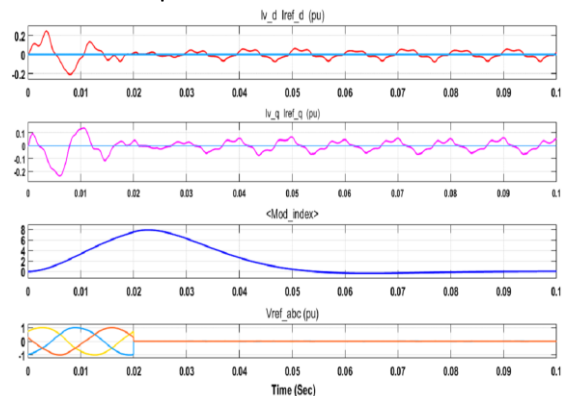

Fig. 14. Station-1 filter performance illustration.

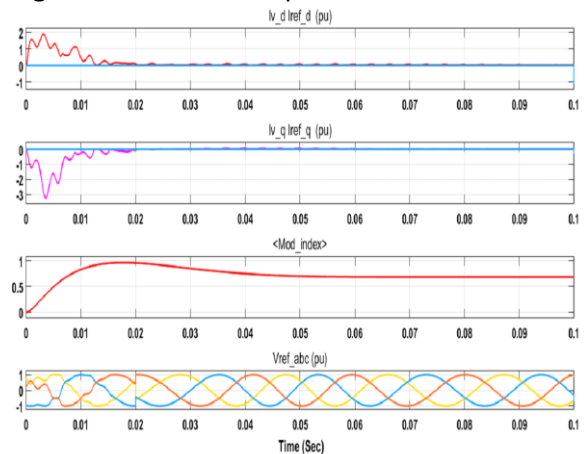

Fig. 15. Station-2 filter performance illustration.

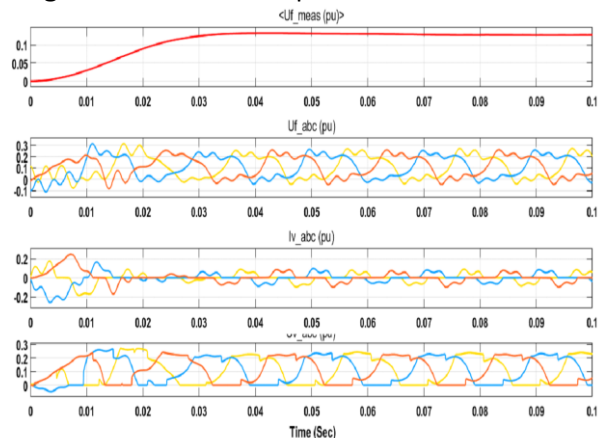

Fig. 16. Station-1 VSC performance illustration

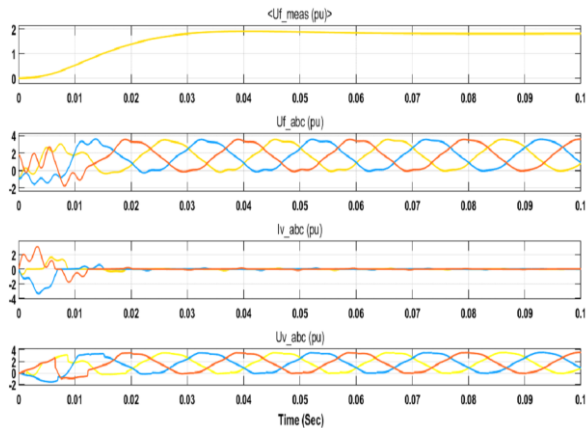

Fig. 17. Station-2 VSC performance illustration.

References

1. A. S. Al-Sumaiti, M. M. A. Salama, S. R. Konda and A. Kavousi-Fard, (2019) "A Guided Procedure for Governance Institutions to Regulate Funding Requirements of Solar PV Projects," in IEEE Access, vol. 7, pp. 54203-54217, doi: 10.1109/ACCESS.2019.2912274.
2. A. Ul-Haq, M. Jalal, H. F. Sindi and S. Ahmad, (2020) "Energy Scenario in South Asia: Analytical Assessment and Policy Implications," in IEEE Access, vol. 8, pp. 156190-156207, doi: 10.1109/ACCESS.2020.3019648.
3. S. P. Bihari et al., (2021) "A Comprehensive Review of Microgrid Control Mechanism and Impact Assessment for Hybrid Renewable Energy Integration," in IEEE Access, vol. 9, pp. 88942-88958, doi: 10.1109/ACCESS.2021.3090266.
4. B. V. Venkatasubramanian, V. Jatily and B. Azzopardi, (2021) "Techno-Economic Framework for Optimal Capacity Expansion of Active Microgrid in the Mediterranean: A Case Study of MCAST," in IEEE Access, vol. 9, pp. 120451-120463, doi: 10.1109/ACCESS.2021.3108959.
5. F. Chishti, S. Murshid and B. Singh, (July, 2020) "Unbiased Circular Leakage Centered Adaptive Filtering Control for Power Quality Improvement of Wind-Solar PV Energy Conversion System," in IEEE Transactions on Sustainable Energy, vol. 11, no. 3, pp. 1347-1357, doi: 10.1109/TSTE.2019.2925089.
6. S. Roy Ghatak, S. Sannigrahi and P. Acharjee, (Sept.,2019) "Multi-Objective Approach for Strategic Incorporation of Solar Energy Source, Battery Storage System, and DSTATCOM in a Smart Grid Environment," in IEEE Systems Journal, vol. 13, no. 3, pp. 3038-3049, doi: 10.1109/JSYST.2018.2875177.
7. E. Du et al., (Nov. 2018) "The Role of Concentrating Solar Power Toward High Renewable Energy Penetrated Power Systems," in IEEE Transactions on Power Systems, vol. 33, no. 6, pp. 6630-6641, doi: 10.1109/TPWRS.2018.2834461.
8. S. Rahman et al., (June 2021) "Analysis of Power Grid Voltage Stability with High Penetration of Solar PV Systems," in IEEE Transactions on Industry Applications, vol. 57, no. 3, pp. 2245-2257, doi: 10.1109/TIA.2021.3066326.
9. D. Chattopadhyay and T. Alpcan, (May 2016) "Capacity and Energy-Only Markets Under High Renewable Penetration," in IEEE Transactions on Power Systems, vol. 31, no. 3, pp. 1692-1702, doi: 10.1109/TPWRS.2015.2461675.
10. J. W. Zapata, M. A. Perez, S. Kouro, A. Lensu and A. Suuronen, (Nov. 2015), "Design of a Cleaning Program for a PV Plant Based on Analysis of Energy Losses," in IEEE Journal of Photovoltaics, vol. 5, no. 6, pp. 1748-1756, doi: 10.1109/JPHOTOV.2015.2478069.
11. I. M. Baht, P. M. Nicolae and M. Ş. Nicolae, (2019) "Impact of Weather Forecasts and Green Building on Micro Grid Energy Management System," International Conference on Electromechanical and Energy Systems (SIELMEN), pp. 1-6, doi: 10.1109/SIELMEN.2019.8905846.
12. S. Khan, A. Salam and S. Alam, (2015) "Facts and popular perceptions on saving energy and the environment," 2015 3rd International Conference on Green Energy and Technology (ICGET), pp. 1-6, doi: 10.1109/ICGET.2015.7315121.

- 13.B. Bora et al., (March 2021), "Failure Mode Analysis of PV Modules in Different Climatic Conditions," in *IEEE Journal of Photovoltaics*, vol. 11, no. 2, pp. 453-460, doi: 10.1109/JPHOTOV.2020.3043847.
- 14.S. B. Raikar and K. M. Jagtap, (2018) "Role of Deregulation in Power Sector and Its Status in India," 2018 National Power Engineering Conference (NPEC), pp. 1-6, doi: 10.1109/NPEC.2018.8476714.
- 15.K. Paul and N. Kumar, (2017) "A review on some aspects of transmission pricing in power system network," 2017 6th International Conference on Computer Applications in Electrical Engineering-Recent Advances (CERA), pp. 175-180, doi: 10.1109/CERA.2017.8343322.
- 16.Z. Wu and S. Li, (July 2019) "Reliability Evaluation and Sensitivity Analysis to AC/UHVDC Systems Based on Sequential Monte Carlo Simulation," in *IEEE Transactions on Power Systems*, vol. 34, no. 4, pp. 3156-3167, doi: 10.1109/TPWRS.2019.2896228.
- 17.L. Zhang et al., (Dec. 2017) "Modeling, control, and protection of modular multilevel converter-based multi-terminal HVDC systems: A review," in *CSEE Journal of Power and Energy Systems*, vol. 3, no. 4, pp. 340-352, doi: 10.17775/CSEEJPES.2017.00440.
- 18.A. Swetapadma, S. Chakrabarti, A. Y. Abdelaziz and H. H. Alhelou, (2021) "A Novel Relaying Scheme Using Long Short-Term Memory for Bipolar High Voltage Direct Current Transmission Lines," in *IEEE Access*, vol. 9, pp. 119894-119906, doi: 10.1109/ACCESS.2021.3107478.
- 19.G. Cao, K. Sun, S. Jiang, S. Lu and Y. Wang, (2018) "A modular DC/DC photovoltaic generation system for HVDC grid connection," in *Chinese Journal of Electrical Engineering*, vol. 4, no. 2, pp. 56-64, doi: 10.23919/CJEE.2018.8409351.
- 20.Y. Hu et al., (2017) "Fault-Tolerant Converter with a Modular Structure for HVDC Power Transmitting Applications," in *IEEE Transactions on Industry Applications*, vol. 53, no. 3, pp. 2245-2256, doi: 10.1109/TIA.2017.2657480.
- 21.B. Li, J. Liu, Z. Wang, S. Zhang and D. Xu, (July 2021) "Modular High-Power DC-DC Converter for MVDC Renewable Energy Collection Systems," in *IEEE Transactions on Industrial Electronics*, vol. 68, no. 7, pp. 5875-5886, doi: 10.1109/TIE.2020.2994878.
- 22.A. Darwish, M. A. Elgenedy, S. J. Finney, B. W. Williams and J. R. McDonald, (March 2019) "A Step-Up Modular High-Voltage Pulse Generator Based on Isolated Input-Parallel/Output-Series Voltage-Boosting Modules and Modular Multilevel Submodules," in *IEEE Transactions on Industrial Electronics*, vol. 66, no. 3, pp. 2207-2216, doi: 10.1109/TIE.2017.2772189.
- 23.C. A. Rojas, S. Kouro, M. A. Perez and J. Echeverria, (Jan. 2018) "DC-DC MMC for HVdc Grid Interface of Utility-Scale Photovoltaic Conversion Systems," in *IEEE Transactions on Industrial Electronics*, vol. 65, no. 1, pp. 352-362, doi: 10.1109/TIE.2017.2714120.
- 24.A. B. Acharya, M. Ricco, D. Sera, R. Teodorescu and L. E. Norum, (Dec. 2019,) "Performance Analysis of Medium-Voltage Grid Integration of PV Plant Using Modular Multilevel Converter," in *IEEE Transactions on Energy Conversion*, vol. 34, no. 4, pp. 1731-1740, doi: 10.1109/TEC.2019.2930819.
- 25.G. Krzywinski, (2015) "Integrating storage and renewable energy sources into a DC Microgrid using high gain DC DC Boost Converters," 2015 IEEE First International Conference on DC Microgrids (ICDCM), pp. 251-256, doi: 10.1109/ICDCM.2015.7152049.
- 26.J. Echeverría, S. Kouro, M. Pérez and H. Abu-rub, (2013) "multi-modular cascaded DC-DC converter for HVDC grid connection of large-scale photovoltaic power systems," *IECON 2013 - 39th Annual Conference of the IEEE Industrial Electronics Society*, pp. 6999-7005, doi: 10.1109/IECON.2013.6700293.
- 27.F. Gao, X. Gu, Z. Ma and C. Zhang, (March 2020),"Redistributed Pulsewidth Modulation of MMC Battery Energy Storage System Under Submodule Fault Condition," in *IEEE Transactions on Power Electronics*, vol. 35, no. 3, pp. 2284-2294, doi: 10.1109/TPEL.2019.2925284.
- 28.C. M. Franck, (April 2011) "HVDC Circuit Breakers: A Review Identifying Future Research Needs," in *IEEE Transactions on Power Delivery*, vol. 26, no. 2, pp. 998-1007, doi: 10.1109/TPWRD.2010.2095889.